

**IPH Series
IP Pump**

**3.6 to 125.9cm³/rev
30MPa**

❖ This is a new design series in which all pump types are installation compatible with previous designs. Note, however, that there is no longer compatibility for some of the seal components between the IPH-3 and IPH-4 sizes and design numbers 10 and 12.

Features

- ① A patented axial and radial pressure loading system provides high efficiency and generates pressures up to 30MPa {306kgf/cm²}.
- ② Outstanding durability and very long life.
- ③ A modified involute short-tooth gear enables internal gearing for greatly reduced pulsation and noise, and exceptionally quiet operation.
- ④ A simple structure makes maintenance and inspection easier.

Specifications

Model No.	Capacity cm ³ /rev	Rated Voltage MPa	Maximum Operating Pressure MPa(kgf/cm ²)	Minimum Revolution Speed min ⁻¹	Maximum Revolution Speed min ⁻¹	Weight kg	
						Type A	Type B
IPH-2A(B)- 3.5-11	3.60	25 {255}	30 {306}	600	2000	4.4	2.4
	5.24					4.5	2.5
	6.55					4.6	2.6
	8.18					4.8	2.8
IPH-3A(B)- 10-20	10.2	25 {255}	30 {306}	600	2000	10.5	4.8
	13.3					10.7	5.0
	15.8					11.0	5.3
IPH-4A(B)- 20-20	20.7	25 {255}	30 {306}	500	2000	15.2	9.5
	25.7					15.7	10.0
	32.3					16.2	10.5
IPH-5A(B)- 40-21(11)	40.8	25 {255}	30 {306}	400	2000	32.0	19.0
	50.3					33.0	20.0
	63.9					34.0	21.0
IPH-6A(B)- 80-21(11)	81.3	25 {255}	30 {306}	300	2000	62.0	39.0
	101.6					64.0	41.0
	125.9					66.0	43.0

- Note)
- 1.Capacity: Logical discharge rate per rotation.
 - 2.Suction Pressure: +0.02 to +0.3MPa {-0.2 to +0.3kgf/cm²}
 - 3.Maximum working pressure shown here is the pressure limit when there are frequent pressure changes.
 - 4.Avoid installation with the suction port towards the bottom of the pump.
 - 5.Specify using the model number format shown below when pipe flanging is required.

● Handling

- ① For the hydraulic operating fluid, use an R&O type and wear-resistant type of ISO VG32 to 68 or equivalent (viscosity index of at least 90). Use hydraulic operating fluid that provides kinematic viscosity during operation in the range of 20 to 150mm²/s.
- ② The operating temperature range is 5 to 65°C. When the oil temperature at

startup is 5°C or less, perform a warm-up operation at low pressure until the oil temperature reaches 5°C. Use the pump in an area where the temperature is within the range of 0 to 60°C.

- ③ Suction pressure is -0.02 to +0.03MPa (-0.2 to +0.3kgf/cm²), and the suction port flow rate should be to greater than 2m/sec.
- ④ Avoid pulley, gear, and other drive systems that impart a radial or thrust load on the end of the pump shaft.
- ⑤ Mount the hydraulic pump so its pump shaft is oriented horizontally. Provide a suction strainer with a filtering grade of about 100μm (150 mesh). For the return line to the tank, use a 25μm line filter.

⑥ Manage hydraulic operating fluid so contamination is maintained at class NAS10 or lower. Take care to avoid contamination with water and other foreign matter, and watch out for discoloration. Whitish fluid indicates that air has contaminated the fluid, and brownish fluid indicates the fluid is dirty.

Understanding Model Numbers

IPH - 4 B - 25 - LT - 20

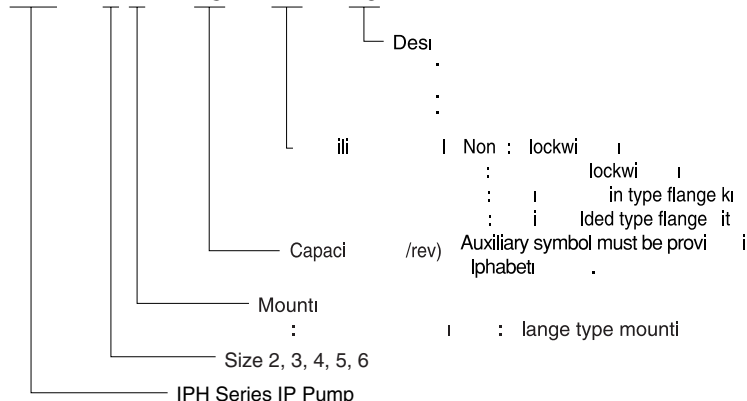

(Continued on following page)

- 7 Operate within the RPM range in the catalog for the minimum RPM of the pump. Unload the pump's load pressure to operate at variable speeds. Condition of inflow piping must produce as little inflow load pressure as possible to minimize effect of cavitation.
- 8 When using water- or glycol-based hydraulic operating fluid, refer to page O-3 for details on applicable models

- of hydraulic pumps.
- 9 At startup, repeat the inching operation (start-stop) to bleed air from the pump and pipes.
- 10 Equip an air bleed valve in circuits where it is difficult to bleed air before startup. See page C-13 for more information.
- 11 To ensure proper lubrication of the pump's rubbing surfaces, supply oil to

- the interior of the pump before starting operation.
- 12 When centering the pump shaft, eccentricity with the motor shaft should be no greater than 0.05mm. Use a pump mounting base of sufficient rigidity. The angle error should be no greater than 1°.
- 13 Contact your agent for information about engines.

Discharge Rate and Required Input for Each Pump Speed

Speed	Pressure MPa Model No.	Discharge Rate ℓ/min						Required Input kW					
		0.7	7	14	21	25	30	0.7	7	14	21	25	30
1000 min ⁻¹	IPH-2A(B)- 3.5-11 5 6.5 8	3.60 5.24 6.55 8.18	3.49 5.09 6.37 7.95	3.39 4.93 6.19 7.74	3.28 4.78 6.03 7.54	3.23 4.70 5.93 7.40	3.15 4.60 5.82 7.26	0.09 0.12 0.16 0.19	0.62 0.79 0.97 1.19	1.12 1.47 1.82 2.24	1.63 2.26 2.79 3.45	1.93 2.63 3.25 4.01	2.30 3.19 3.95 4.86
	IPH-3A(B)- 10-20 13 16	10.2 13.3 15.8	9.95 13.0 15.4	9.71 12.7 15.1	9.47 12.4 14.8	9.23 12.3 14.6	9.17 12.1 14.3	0.25 0.32 0.37	1.59 2.02 2.37	2.73 3.57 4.23	4.25 5.35 6.35	5.06 6.29 7.47	6.14 7.73 9.19
	IPH-4A(B)- 20-20 25 32	20.7 25.7 32.3	20.2 25.2 31.6	19.8 24.7 31.0	19.3 24.2 30.4	19.1 23.9 30.1	18.8 23.6 29.6	0.50 0.61 0.75	3.13 3.79 4.71	5.56 6.89 8.67	8.24 10.3 12.8	9.80 12.1 15.3	11.7 14.6 18.4
	IPH-5A(B)- 40-21(11) 50 64	40.8 50.3 63.9	39.9 49.3 62.6	39.0 48.4 61.4	38.1 47.3 60.2	37.6 46.8 59.5	37.0 46.2 58.6	0.99 1.20 1.49	6.18 7.42 9.32	10.9 13.6 17.2	16.3 20.1 25.5	19.3 23.8 30.6	23.8 28.6 36.3
	IPH-6A(B)- 80-21(11) 100 125	81.3 101.6 125.9	79.5 99.6 123.4	77.7 97.7 121.1	76.0 95.8 118.7	75.1 94.6 117.2	73.8 93.2 115.6	1.98 2.42 2.94	11.8 14.6 17.8	21.8 27.3 33.9	32.3 40.5 50.1	38.4 48.1 59.6	46.7 57.7 71.5
1200 min ⁻¹	IPH-2A(B)- 3.5-11 5 6.5 8	4.32 6.28 7.86 9.81	4.20 6.12 7.67 9.58	4.08 5.95 7.48 9.34	3.97 5.79 7.29 9.11	3.91 5.70 7.18 8.97	3.83 5.58 7.05 8.81	0.11 0.15 0.19 0.23	0.66 0.95 1.16 1.44	1.23 1.77 2.19 2.70	1.83 2.62 3.24 4.00	2.15 3.09 3.81 4.70	2.61 3.74 4.63 5.71
	IPH-3A(B)- 10-20 13 16	12.2 15.9 18.9	11.9 15.9 18.5	11.7 15.3 18.2	11.4 15.0 17.8	11.3 14.8 17.6	11.1 14.6 17.4	0.30 0.39 0.45	1.86 2.37 2.77	3.28 4.28 5.09	4.93 6.42 7.63	5.93 7.56 8.98	7.20 9.28 11.1
	IPH-4A(B)- 20-20 25 32	24.8 30.8 38.7	24.3 30.3 38.1	23.8 29.8 37.4	23.4 29.3 36.8	23.1 29.0 36.3	22.8 28.6 35.9	0.62 0.75 0.92	3.76 4.56 5.66	6.67 8.27 10.4	9.88 12.3 15.5	11.8 14.7 18.4	14.2 17.5 22.0
	IPH-5A(B)- 40-21(11) 50 64	48.9 60.3 76.6	48.0 59.3 75.3	47.1 58.3 74.0	46.1 57.3 72.8	45.5 56.6 72.0	44.9 56.0 71.2	1.22 1.47 1.83	7.42 8.91 11.2	13.2 16.2 20.6	19.5 24.0 30.5	23.1 28.6 36.3	28.4 34.3 43.5
	IPH-6A(B)- 80-21(11) 100 125	97.5 121.9 151.0	95.7 119.7 148.4	93.8 117.7 145.9	91.9 115.8 143.4	90.9 114.5 141.9	89.5 113.1 140.3	2.42 2.96 3.60	14.3 17.5 21.5	26.2 32.3 40.1	38.7 48.4 60.1	46.2 57.7 71.6	56.1 69.2 85.9
1500 min ⁻¹	IPH-2A(B)- 3.5-11 5 6.5 8	5.40 7.86 9.82 12.3	5.25 7.65 9.59 11.9	5.10 7.44 9.35 11.6	4.97 7.24 9.12 11.4	4.89 7.11 8.97 11.2	4.79 6.97 8.82 11.0	0.14 0.20 0.25 0.30	0.96 1.17 1.49 1.78	1.68 2.21 2.73 3.37	2.46 3.31 4.09 5.05	2.89 3.85 4.76 5.87	3.46 4.69 5.78 7.14
	IPH-3A(B)- 10-20 13 16	15.3 19.9 23.7	14.9 19.5 23.2	14.6 19.1 22.7	14.3 18.8 22.3	14.1 18.6 22.1	13.9 18.3 21.8	0.40 0.51 0.59	2.31 2.95 3.46	4.15 5.41 6.42	6.22 8.03 9.53	7.40 9.44 11.2	8.99 11.6 13.8
	IPH-4A(B)- 20-20 25 32	31.0 38.5 48.4	30.4 37.8 47.6	29.8 37.2 46.8	29.3 36.6 45.9	28.9 36.1 45.4	28.4 35.7 44.9	0.81 0.98 1.20	4.70 5.69 7.07	8.33 10.4 13.1	12.4 15.4 19.3	14.7 18.3 22.9	17.6 21.9 27.5
	IPH-5A(B)- 40-21(11) 50 64	61.2 75.4 95.8	60.0 74.1 94.2	58.8 72.8 92.5	57.6 71.6 91.0	56.9 70.8 90.0	56.2 70.0 89.0	1.59 1.91 2.38	9.51 11.4 14.4	16.6 20.5 26.0	24.7 30.4 38.6	29.3 36.1 45.9	36.0 43.3 55.1
	IPH-6A(B)- 80-21(11) 100 125	121.9 152.4 188.8	119.5 149.7 185.5	117.3 147.3 182.5	115.0 144.7 179.3	113.5 143.2 177.5	111.9 141.5 175.3	3.16 3.86 4.69	18.3 22.5 27.5	33.1 41.4 51.3	49.0 61.4 76.0	58.4 73.0 90.4	70.9 87.6 108.1
1800 min ⁻¹	IPH-2A(B)- 3.5-11 5 6.5 8	6.48 9.43 11.7 14.7	6.33 9.21 11.5 14.4	6.16 8.99 11.2 14.1	6.01 8.76 11.0 13.7	5.92 8.61 10.9 13.6	5.82 8.46 10.7 13.3	0.17 0.24 0.30 0.37	1.16 1.45 1.78 2.20	2.02 2.65 3.27 4.04	2.95 3.47 4.92 6.06	3.46 4.62 5.71 7.05	4.15 5.61 6.93 8.56
	IPH-3A(B)- 10-20 13 16	18.3 23.9 28.4	18.0 23.5 27.9	17.6 23.1 27.5	17.3 22.7 27.0	17.1 22.5 26.7	16.8 22.2 26.4	0.49 0.62 0.72	2.90 3.67 4.30	5.04 6.57 7.80	7.47 9.63 11.4	8.89 11.3 13.5	10.8 13.9 16.5
	IPH-4A(B)- 20-20 25 32	37.2 46.2 58.1	36.6 45.6 57.3	36.0 44.9 56.5	35.4 44.3 55.5	35.0 43.8 54.8	34.5 43.3 54.5	0.99 1.20 1.48	5.64 6.83 8.47	10.0 12.4 15.6	14.9 18.5 23.1	17.6 21.9 27.5	21.2 26.3 33.0
	IPH-5A(B)- 40-21(11) 50 64	73.4 90.5 115.0	72.1 89.2 113.4	70.9 87.9 111.6	69.7 86.6 110.0	69.0 85.9 109.1	68.1 85.0 108.0	1.95 2.34 2.92	11.7 14.1 17.6	20.2 24.9 31.6	30.0 36.9 46.8	35.6 43.8 55.7	43.7 52.6 66.9
	IPH-6A(B)- 80-21(11) 100 125	146.3 182.8 226.6	143.7 180.2 223.3	141.4 177.6 220.1	139.0 174.9 216.9	137.5 173.5 215.0	135.8 171.7 212.7	3.88 4.74 5.75	22.4 27.7 33.8	40.2 50.3 62.2	59.6 74.4 92.3	70.9 88.6 110.0	86.1 106.0 131.5

Note) Values in the table are general values at an operating fluid viscosity of 46mm²/s. Use the values when selecting the model for your needs.

Installation Dimension Drawings

IPH-2A-*-11 (Foot Mounting, Clockwise Rotation)

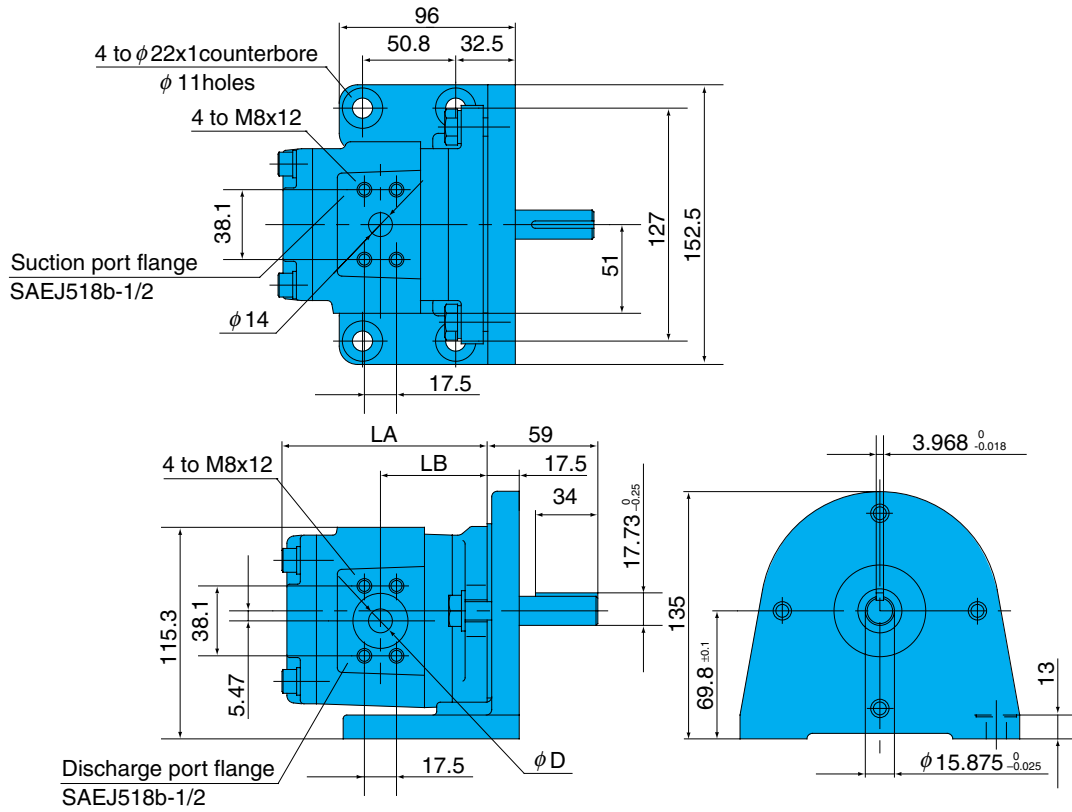

IPH-2B-*-11 (Flange Mounting, Clockwise Rotation)

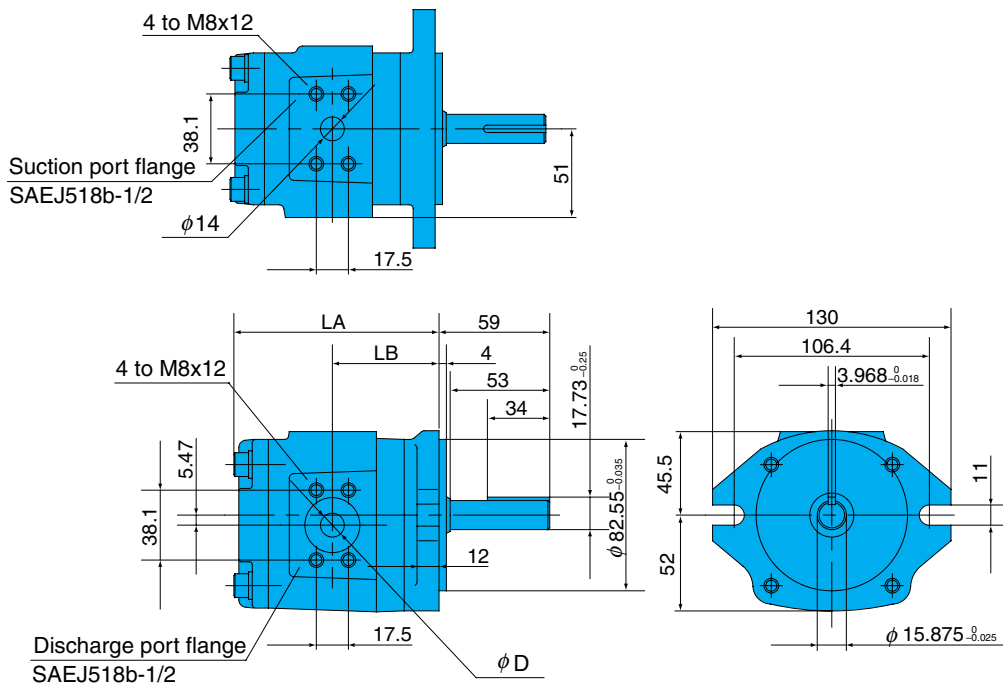

Model No.	Dimensions (mm)		
	LA	LB	ϕD
IPH-2*-3.5-*-11	107	51.0	8.9
IPH-2*-5-*-11	112	53.5	11
IPH-2*-6.5-*-11	116	55.5	12
IPH-2*-8-*-11	121	58.0	13

Note) IPH-2A (B)-*-L-11 (foot mounting/flange mounting, counterclockwise rotation) are the mirror image of the drawings shown above. In the case the suction port flange is facing upwards, the discharge port flange is positioned to the right when viewed from the shaft side.

IPH-3A-*-20 (Foot Mounting, Clockwise Rotation)

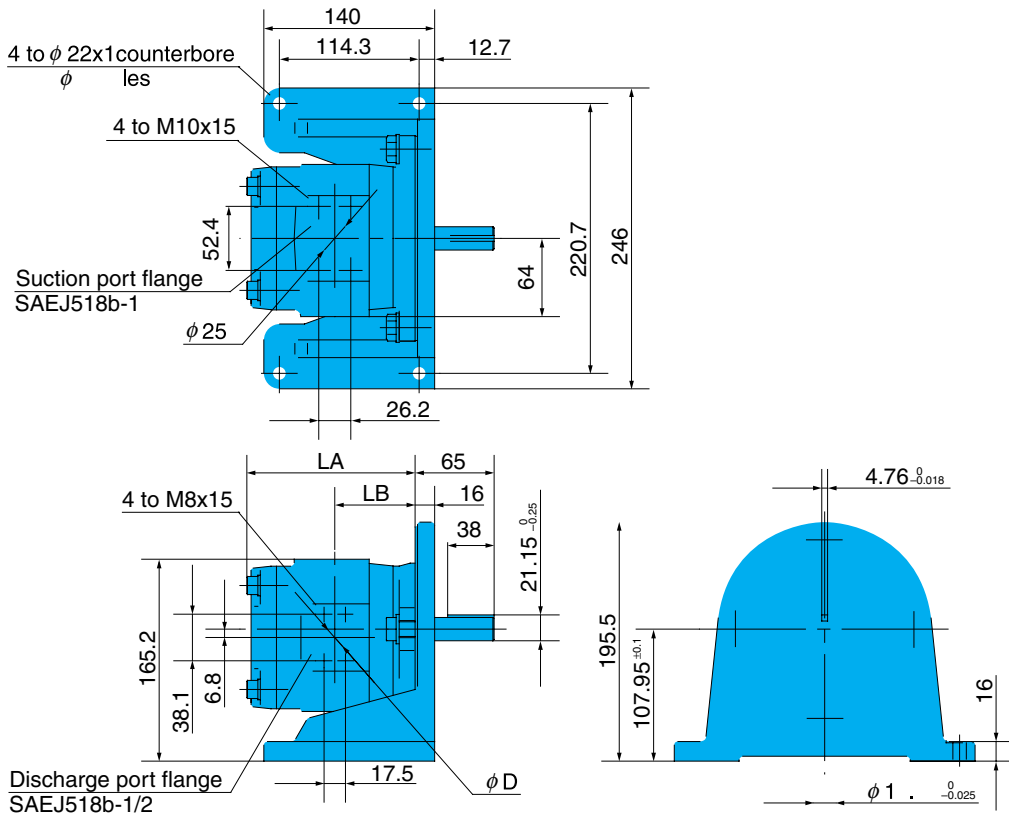

IPH-3B-*-20 (Flange Mounting, Clockwise Rotation)

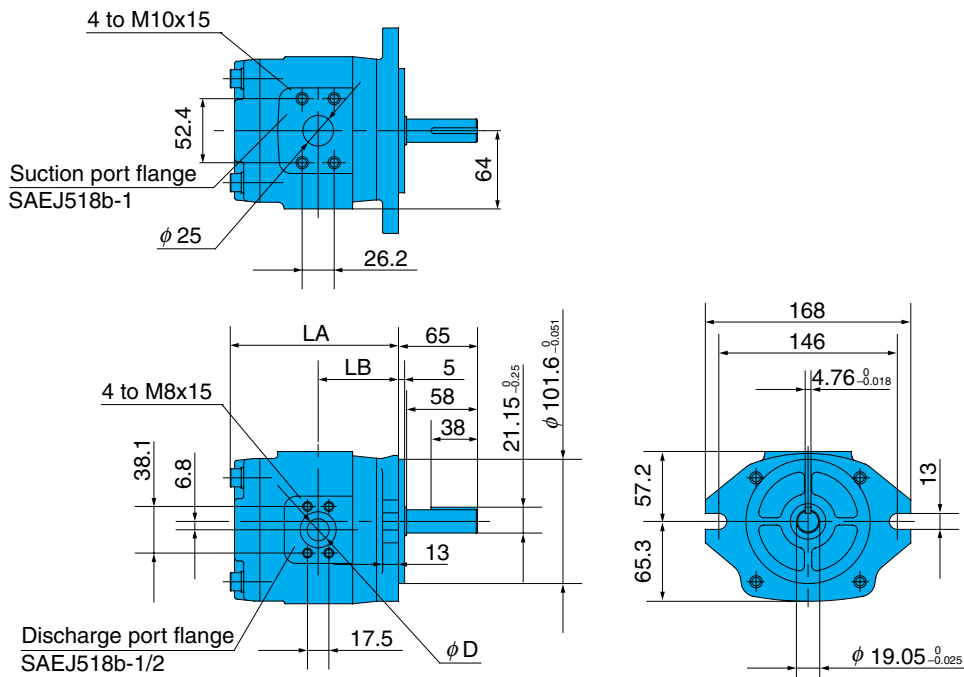

Model No.	Dimensions (mm)		
	LA	LB	ϕD
IPH-3*-10-*-20	128.5	60.0	14
IPH-3*-13-*-20	134.5	63.0	17
IPH-3*-16-*-20	139.5	65.5	18

Note) IPH-3A (B)-*-L-20 (foot mounting/flange mounting, counterclockwise rotation) are the mirror image of the drawings shown above. In the case the suction port flange is facing upwards, the discharge port flange is positioned to the right when viewed from the shaft side.

IPH-4A-* -20 (Foot Mounting, Clockwise Rotation)

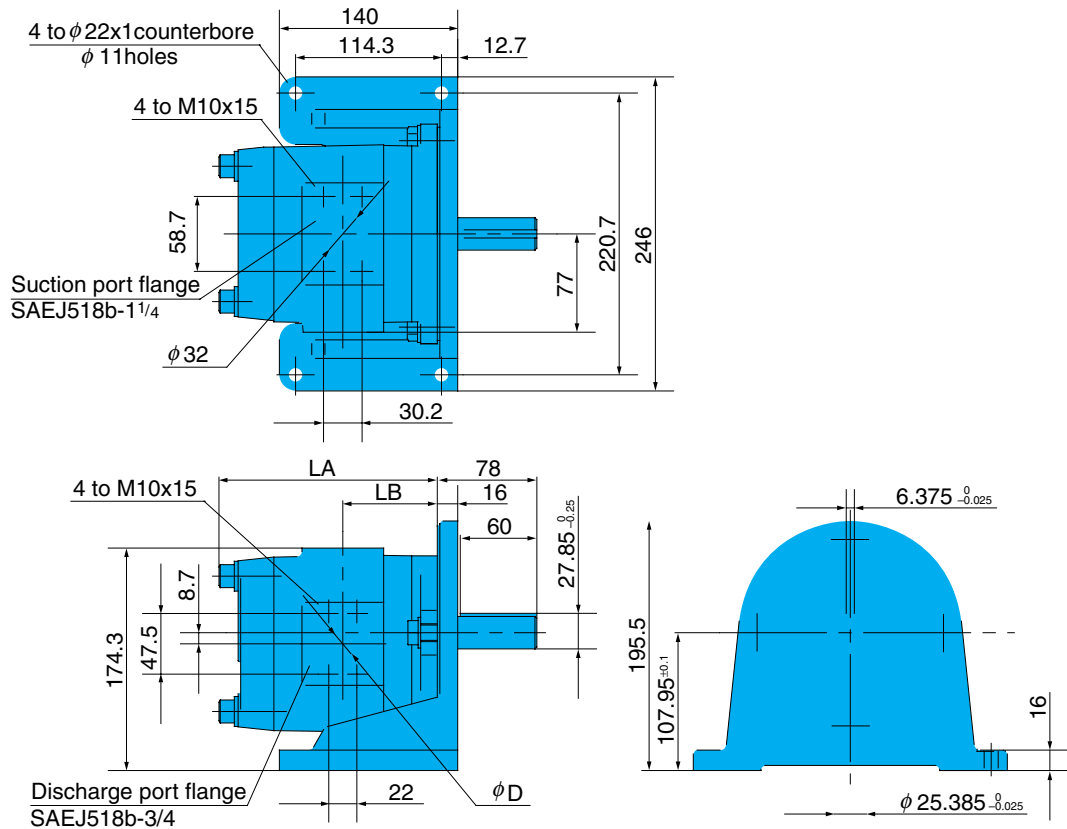

IPH-4B-* -20 (Flange Mounting, Clockwise Rotation)

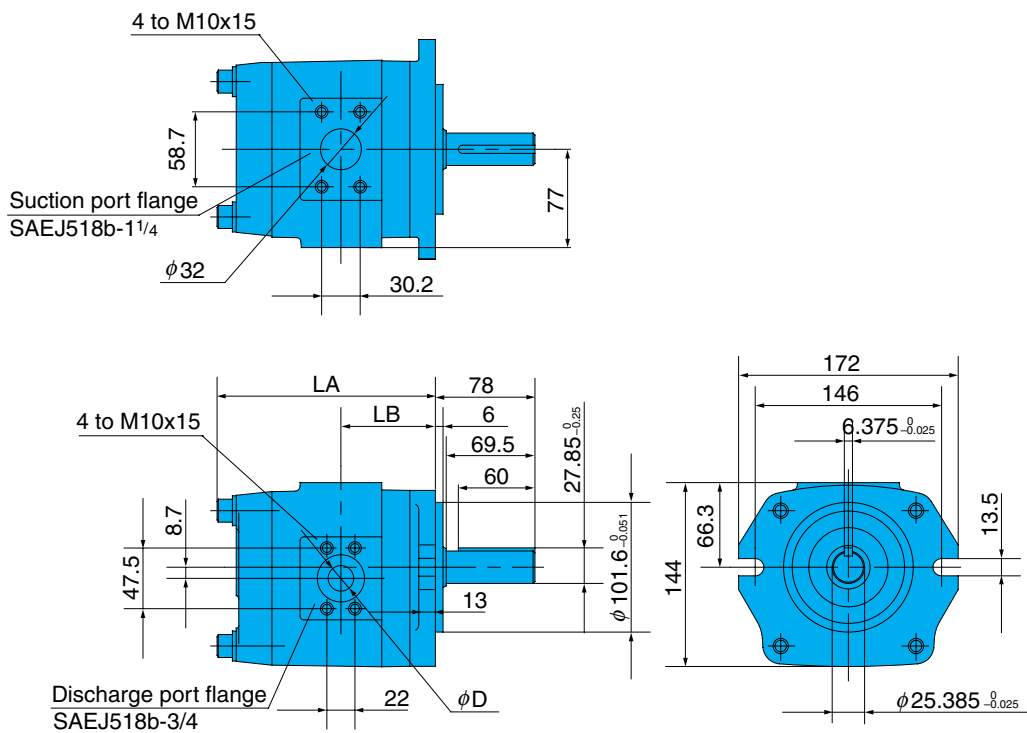

Model No.	Dimensions (mm)		
	LA	LB	ϕD
IPH-4*-20*-20	164.5	71	18
IPH-4*-25*-20	170.5	74	20
IPH-4*-32*-20	178.5	78	24

Note) IPH-4A (B)-*-L-20 (foot mounting/flange mounting, counterclockwise rotation) are the mirror image of the drawings shown above. In the case the suction port flange is facing upwards, the discharge port flange is positioned to the right when viewed from the shaft side.

IPH-6A-*-21 (Foot Mounting, Clockwise Rotation)

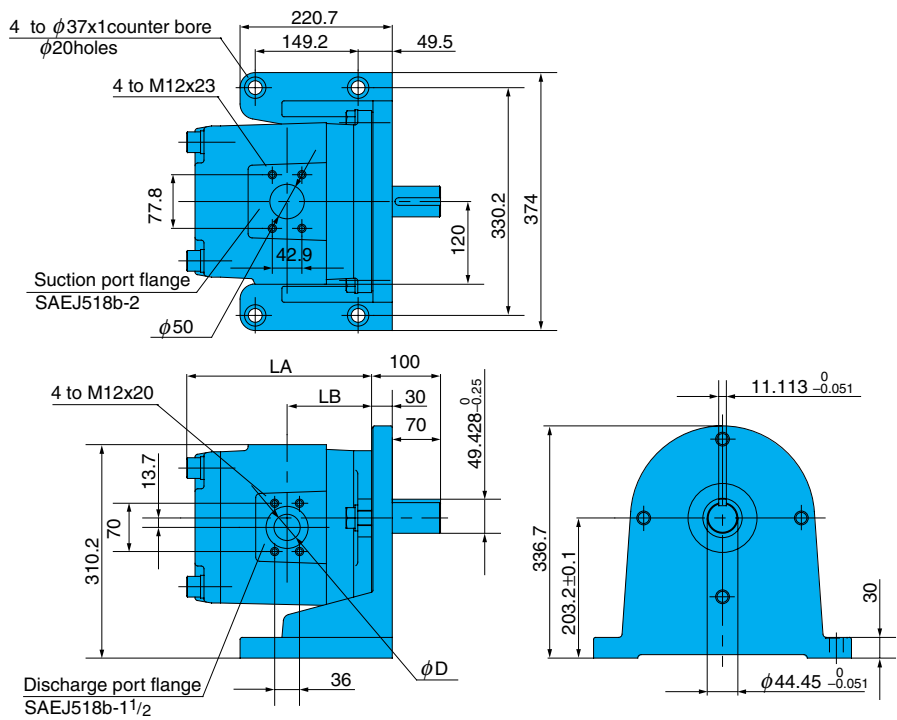

IPH-6B-*-11 (Flange Mounting, Clockwise Rotation)

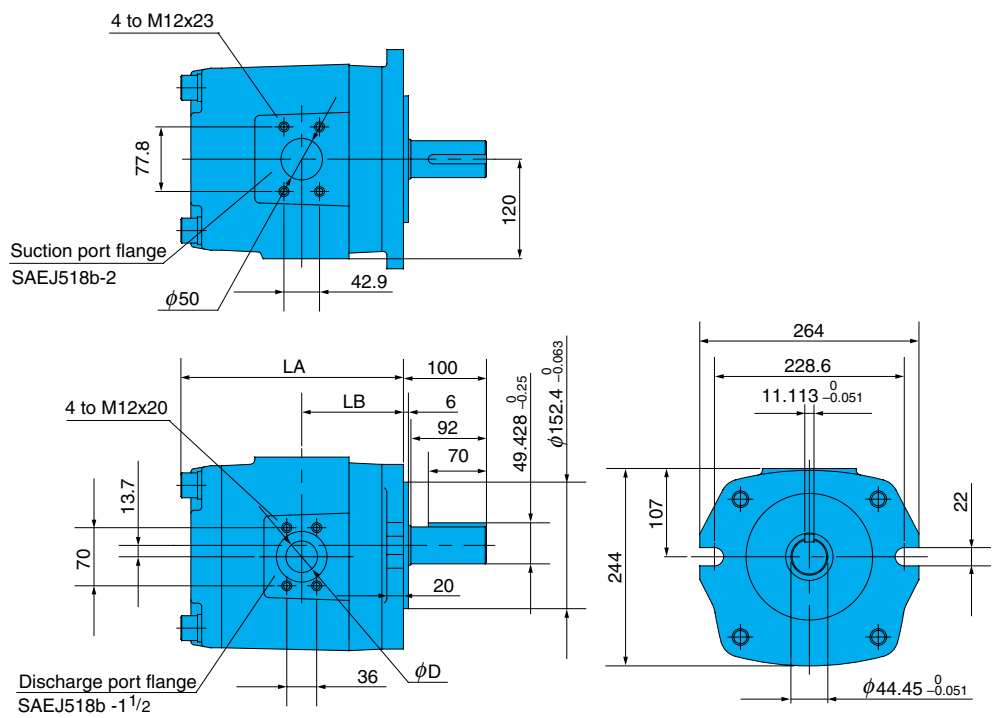

Model No.	Dimensions (mm)		
	LA	LB	ϕD
IPH-6*- 80-*-21 (11)	241.5	111.5	32
IPH-6*-100-*-21 (11)	251.5	116.5	36
IPH-6*-125-*-21 (11)	263.5	122.5	38

Note) IPH-6A (B)-*-L-21 (11) (foot mounting/flange mounting, counterclockwise rotation) are the mirror image of the drawings shown above. In the case the suction port flange is facing upwards, the discharge port flange is positioned to the right when viewed from the shaft side.

Performance Curves

Revolution Speed 1200min⁻¹
 Operating Hydraulic Fluid Viscosity 46mm²/s
 Representative Characteristics Under Above Conditions

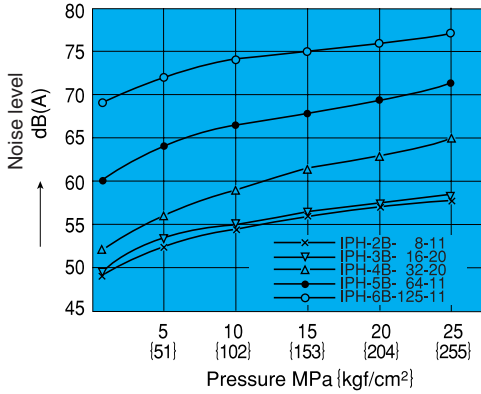
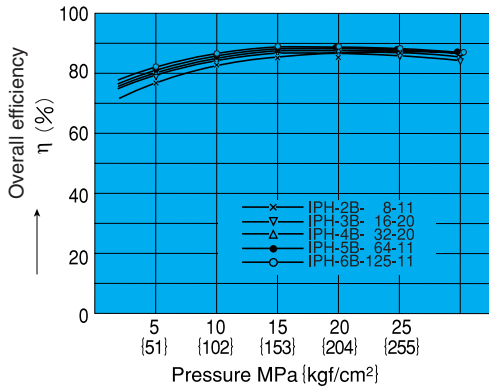
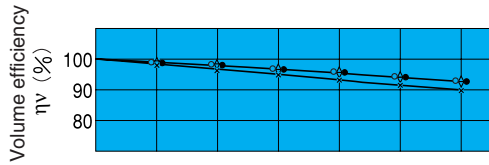

Cross-sectional Drawing

IPH-*B-*-*

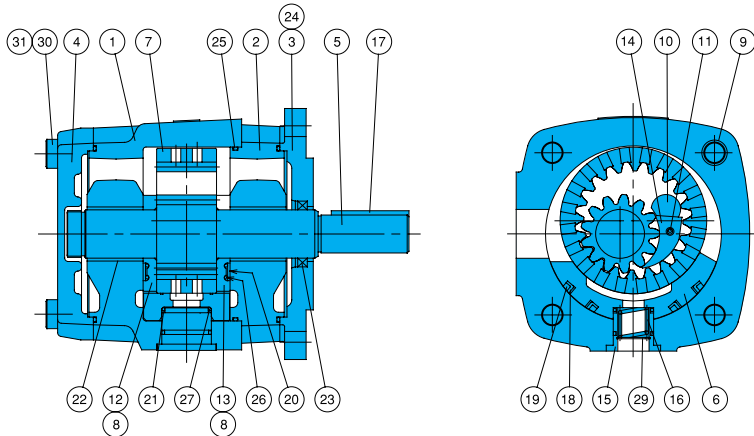

Note) Drawings shown above are the IPH-5 and IPH-6.
 The lower left cross-sectional drawing is the IPH-4, the radial seal #18 was removed and a wave washer was added. The lower right cross-sectional drawing is the IPH-2 and IPH-3, the bushing #8 was removed, the spring pin #11 was replaced with a guide pin, and the radial seal #18 was removed and a wave washer #32 was added.

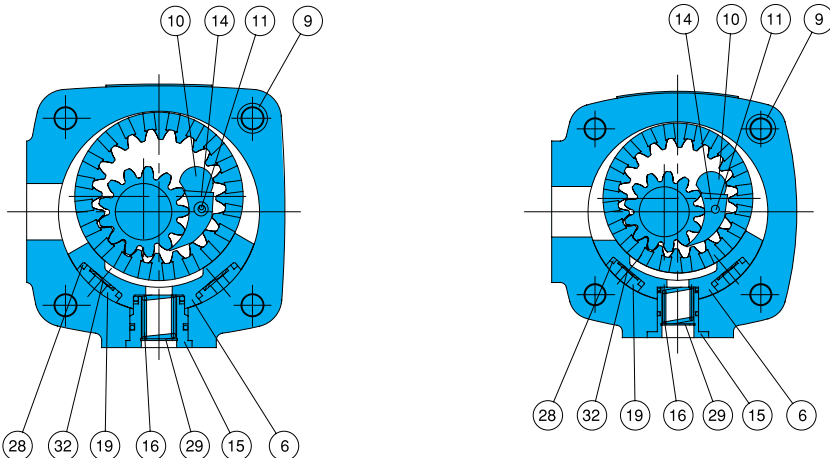

Part No.	Part Name
1	Body -1
2	Body -2
3	Mounting
4	Rear cover
5	Pinion shaft
6	Radial piston
7	Internal gear
8	Bushing
9	Knock pin
10	Stopper pin
11	Spring pin (guide pin)
12	Axial plate -1
13	Axial plate -2
14	Feeler piece
15	Spring holder
16	Spring
17	Key
18	Radial seal
19	Radial backup ring
20	Axial backup ring
21	Backup ring
22	Bearing
23	Oil seal
24	Pin
25	O-ring
26	O-ring
27	O-ring
28	O-ring
29	Snap ring
30	Screw
31	Washer
32	Wave washer



IPH Series Seal Kit

Understanding Seal Kit **IHAS - 2 S * ** - 10(20, 30)**

Model Numbers :

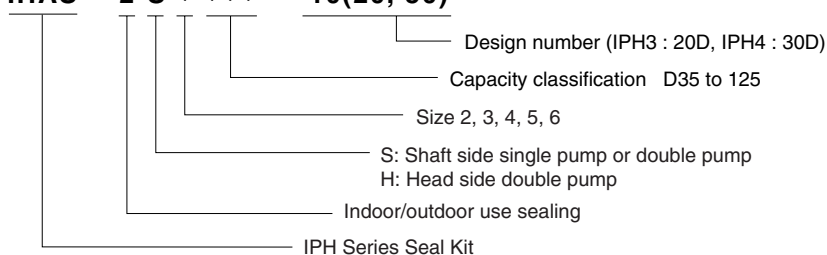

Seal Kit Number	Applicable Pump Model No.	Component Part Numbers							
		18	Qty	19	Qty	20	Qty	21	Qty
		Radial Seal		Radial Backup Ring		Axial Backup Ring		Backup ring	
IHAS-2S2D35-10	IPH-2A(B)-3.5-11			IH34J-102D35-1A	2	IH34J-202000	2	IH34J-402D35	1
2S2005-10	5			102005-1A	2	"	2	402005	1
2S2D65-10	6.5			102D65-1A	2	"	2	402D65	1
2S2008-10	8			102008-1A	2	"	2	402008	1
IHAS-2S3010-20	IPH-3A(B)-10-20			IH34J-103010-1A	2	IH34J-203000	2	IH34J-403010	1
2S3013-20	13			103013-1A	2	"	2	403013	1
2S3016-20	16			103016-1A	2	"	2	403016	1
IHAS-2S4020-30	IPH-4A(B)-20-20			IH34J-104020-2A	2	IH34J-204000-1A	2	IH34J-404020	1
2S4025-30	25			104025-2A	2	"	2	404025	1
2S4032-30	32			104032-2A	2	"	2	404032	1
IHAS-2S5040-10	IPH-5A(B)-40-21(11)	IH33J-105040-1A	2	IH34J-105040-1A	2	IH34J-205000	2	IH34J-405040	1
2S5050-10	50	105050-1A	2	105050-1A	2	"	2	405050	1
2S5064-10	64	105064-1A	2	105064-1A	2	"	2	405064	1
IHAS-2S6080-10	IPH-6A(B)-80-21(11)	IH33J-106080-1A	2	IH34J-106080-1A	2	IH34J-206000	2	IH34J-406080	1
2S6100-10	100	106100-1A	2	106100-1A	2	"	2	406100	1
2S6125-10	125	106125-1A	2	106125-1A	2	"	2	406125	1

Seal Kit Number	Component Part Numbers									
	23	Qty	25	Qty	26	Qty	27	Qty	28	Qty
	Oil seal		O-ring		O-ring		O-ring		O-ring	
IHAS-2S2D35-10	ISD-20328	1	R68 × 2	3	R23 × 2	2	R10 × 2	1	R10 × 2	2
2S2005-10	"	1	"	3	"	2	R12 × 2	1	R12 × 2	2
2S2D65-10	"	1	"	3	"	2	R14 × 2	1	R14 × 2	2
2S2008-10	"	1	"	3	"	2	R16 × 2	1	R16 × 2	2
IHAS-2S3010-20	ISD-25388	1	R86 × 2	3	R30 × 2	2	R15 × 2.5	1	R15 × 2.5	2
2S3013-20	"	1	"	3	"	2	R18 × 2.5	1	R18 × 2.5	2
2S3016-20	"	1	"	3	"	2	R20 × 2.5	1	R20 × 2.5	2
IHAS-2S4020-30	ISD-32458	1	R108 × 3	3	R38 × 2.5	2	R21 × 2.5	1	R21 × 2.5	2
2S4025-30	"	1	"	3	"	2	R23 × 3	1	R23 × 3	2
2S4032-30	"	1	"	3	"	2	R26 × 3	1	R26 × 3	2
IHAS-2S5040-10	ISD-40558	1	R140 × 3	3	R49 × 3	2	R26 × 3	1		
2S5050-10	"	1	"	3	"	2	R29 × 3.5	1		
2S5064-10	"	1	"	3	"	2	R33 × 3.5	1		
IHAS-2S6080-10	ISD-50659	1	R172 × 4	3	R60 × 3.5	2	R34 × 3.5	1		
2S6100-10	"	1	"	3	"	2	R38 × 4	1		
2S6125-10	"	1	"	3	"	2	R43 × 4	1		

Note) 1.Oil seals are manufactured by Nippon Oil Seal Industry Co. Ltd. (NOK).
2.O-rings are not available through retail sources. Consult your agent for more information.

IPH Series Pipe Flange Kit

Understanding Flange Kit Model Numbers :

The pipe flange kit combines the flanges, bolts, washers, and O-rings required for each type of pump into a single kit.

The component parts table shows the screw in type flange kit. In the case of the welded type flange, the flange part number is IH03J-200040 (1 of IH03J-100040 changes to 2). All other included parts are the same.

IHF - 3 - T - 20

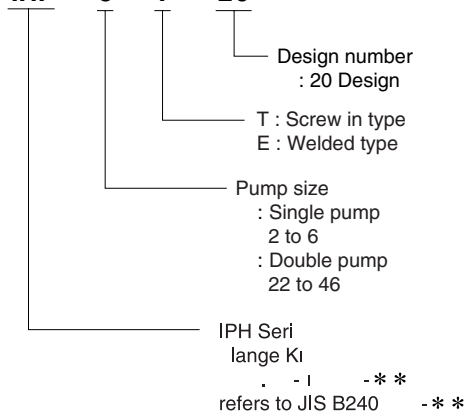

Screw in type Flange Kit model No.	Applicable Pump Model No.	IN Flange							
		Flange Part No.		Bolt		Washer		O-ring	
IHF-2-T-20	IPH-2A(B)-*-11	IH03J-100040	1	TH- 8 × 45	4	WS-B- 8	4	IB-P22	1
IHF-3-T-20	IPH-3A(B)-*-20	IH03J-100080	1	TH-10 × 50	4	WS-B-10	4	IB-G35	1
IHF-4-T-20	IPH-4A(B)-*-20	IH03J-100100	1	TH-10 × 55	4	"	4	IB-G40	1
IHF-5-T-20	IPH-5A(B)-*-21(11)	IH03J-100120	1	TH-12 × 55	4	WS-B-12	4	IB-G50	1
IHF-6-T-20	IPH-6A(B)-*-21(11)	IH03J-100160	1	TH-12 × 60	4	"	4	IB-G60	1

OUT Flange								Plug	
Flange Part No.		Bolt		Washer		O-ring			
IH03J-100040	1	TH- 8 × 45	4	WS-B- 8	4	IB-P22	1	TPHA-1/4	2
IH03J-100040	1	TH- 8 × 45	4	"	4	IB-P22	1	"	2
IH03J-100060	1	TH-10 × 50	4	WS-B-10	4	IB-G30	1	"	1
IH03J-100080	1	TH-10 × 50	4	"	4	IB-G35	1	"	2
IH03J-100120	1	TH-12 × 60	4	WS-B-12	4	IB-G50	1	"	1

Note)1. In the case of a double pump, the flange kit includes three flanges: one for the common IN port and two OUT port flanges. When using separate IN ports, use separate single pump flange kits, one each for the head side and the shaft side.

Note)2. There is no common IN port in the case of the double pump models IPH-55, IPH-56, and IPH-66, or a single IN port is used.

Screw in type Flange Kit model No.	Applicable Pump Model No.	IN Flange							
		Flange Part No.		Bolt		Washer		O-ring	
IHF-22-T-20	IPH- 22B-*-*-11	IH03J-100060	1	TH-10 × 50	4	WS-B-10	4	IB-G30	1
IHF-23-T-20	23	IH03J-100080	1	"	4	"	4	IB-G35	1
IHF-24-T-20	24	IH03J-100120	1	TH-12 × 55	4	WS-B-12	4	IB-G50	1
IHF-25-T-20	25	IH03J-100160	1	TH-12 × 60	4	"	4	IB-G60	1
IHF-26-T-20	26	IH03J-100200	1	TH-12 × 65	4	"	4	IB-G75	1
IHF-33-T-20	IPH- 33B-*-*-11	IH03J-100100	1	TH-10 × 55	4	WS-B-10	4	IB-G40	1
IHF-34-T-20	34	IH03J-100120	1	TH-12 × 55	4	WS-B-12	4	IB-G50	1
IHF-35-T-20	35	IH03J-100160	1	TH-12 × 60	4	"	4	IB-G60	1
IHF-36-T-20	36	IH03J-100200	1	TH-12 × 60	4	"	4	IB-G75	1
IHF-44-T-20	IPH- 44B-*-*-11	IH03J-100120	1	TH-12 × 55	4	"	4	IB-G50	1
IHF-45-T-20	45	IH03J-100200	1	TH-12 × 65	4	"	4	IB-G75	1
IHF-46-T-20	46	IH03J-100240	1	TH-16 × 75	4	WS-B-16	4	IB-G85	1

OUT Flange (Shaft Side)							OUT Flange (Head Side)							Plug			
Flange Part No.		Bolt		Washer		O-ring		Flange Part No.		Bolt		Washer			O-ring		
IH03J-100040	1	TH- 8 × 45	4	WS-B- 8	4	IB-P22	1	IH03J-100040	1	TH- 8 × 45	4	WS-B- 8	4	IB-P22	1	TPHA-1/4	3
IH03J-100040	1	"	4	"	4	IB-P22	1	"	1	"	4	"	4	"	1	"	3
IH03J-100060	1	TH-10 × 50	4	WS-B-10	4	IB-G30	1	"	1	"	4	"	4	"	1	"	3
IH03J-100080	1	"	4	"	4	IB-G35	1	"	1	"	4	"	4	"	1	"	2
IH03J-100120	1	TH-12 × 60	4	WS-B-12	4	IB-G50	1	"	1	"	4	"	4	"	1	"	2
IH03J-100040	1	TH- 8 × 45	4	WS-B- 8	4	IB-P22	1	IH03J-100040	1	TH- 8 × 45	4	WS-B- 8	4	IB-P22	1	"	2
IH03J-100060	1	TH-10 × 50	4	WS-B-10	4	IB-G30	1	"	1	"	4	"	4	"	1	"	3
IH03J-100080	1	"	4	"	4	IB-G35	1	"	1	"	4	"	4	"	1	"	2
IH03J-100120	1	TH-12 × 60	4	WS-B-12	4	IB-G50	1	"	1	"	4	"	4	"	1	"	2
IH03J-100060	1	TH-10 × 50	4	WS-B-10	4	IB-G30	1	IH03J-100060	1	TH-10 × 50	4	WS-B-10	4	IB-G30	1	"	3
IH03J-100080	1	"	4	"	4	IB-G35	1	"	1	"	4	"	4	"	1	"	2
IH03J-100120	1	TH-12 × 60	4	WS-B-12	4	IB-G50	1	"	1	"	4	"	4	"	1	"	2

Pipe Flange Installation Dimension Diagram

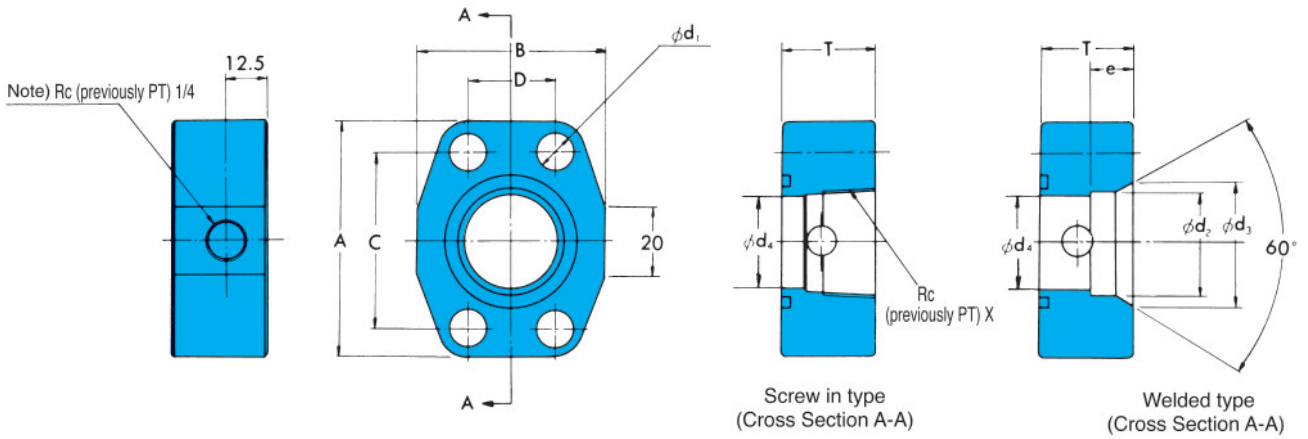

Screw in type

Pipe Flange Kit Part Number	SAE Standard	Nominal Diameter	Dimensions (mm)							Weight kg
			A	B	C	D	T	ϕd_1	ϕd_4	
IH03J -100040	SAE J518b 1/2	1/2	54	46	38.1	17.5	33	9	12.7	0.4
-100060	SAE J518b 3/4	3/4	65	52	47.5	22.0	33	11	20	0.6
-100080	SAE J518b 1	1	70	59	52.4	26.2	33	11	27	0.6
☆ -100100	SAE J518b 1 1/4	1 1/4	79	73	58.7	30.2	38	11	33	1.0
-100120	SAE J518b 1 1/2	1 1/2	94	83	70.0	36.0	38	13	37.5	1.4
☆ -100160	SAE J518b 2	2	102	97	77.8	42.9	38	13	50	1.7
☆ -100200	SAE J518b 2 1/2	2 1/2	114	109	88.9	50.8	43	13	60	2.1
☆ -100240	SAE J518b 3	3	135	131	106.4	61.9	48	17.5	71	3.3

Welded Type

Pipe Flange Kit Part Number	SAE Standard	Pipe Diameter	Dimensions (mm)										Weight kg
			A	B	C	D	T	e	ϕd_1	ϕd_2	ϕd_3	ϕd_4	
IH03J -200040	SAE J518b 1/2	1/2	54	46	38.1	17.5	33	11	9	22.2	27	12.7	0.4
-200060	SAE J518b 3/4	3/4	65	52	47.5	22.0	33	12	11	27.7	35	20	0.6
-200080	SAE J518b 1	1	70	59	52.4	26.2	33	14	11	34.5	42	27	0.6
☆ -200100	SAE J518b 1 1/4	1 1/4	79	73	58.7	30.2	38	16	11	43.2	48	33	1.0
-200120	SAE J518b 1 1/2	1 1/2	94	83	70.0	36.0	38	18	13	49.1	58	37.5	1.4
☆ -200160	SAE J518b 2	2	102	97	77.8	42.9	38	19	13	61.1	68	50	1.7
☆ -200200	SAE J518b 2 1/2	2 1/2	114	109	88.9	50.8	43	22	13	77.1	82	60	2.1
☆ -200240	SAE J518b 3	3	135	131	106.4	61.9	48	25	17.5	90.0	97	71	3.3

Recommended Tightening Torque for Flange Installation Bolts

For aluminum body

For cast body (shared IN port)

Mounting bolt	Tightening Torque N · m {kgf · cm}
M8	19.6 to 23.5 {200 to 240}
M10	49.0 to 58.8 {500 to 600}
M12	88.2 to 112.7 {900 to 1150}

Mounting bolt	Tightening Torque N · m {kgf · cm}
M10	50 to 65 { 510 to 662}
M12	88 to 112 { 898 to 1140}
M16	215 to 275 {2192 to 2800}

Note) There is no RC (previously PT) 1/4 tap for the above flange numbers (exclusively for suction port use) marked with a star (☆).

IPH Series Foot Mounting Kit

Understanding Foot Mounting Kit Numbers:

When only the mounting feet are required for a single pump or double pump, pump mounting bolts, washers and other parts are sold together as the Foot Mounting Kit.

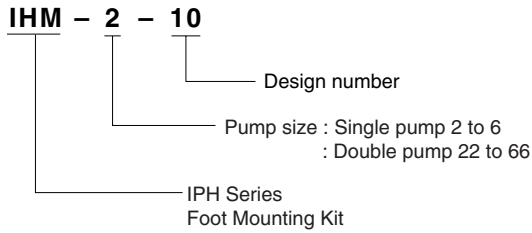

Foot Mounting Installation Measurement Chart
SAE-2BOLT-MOUNTING

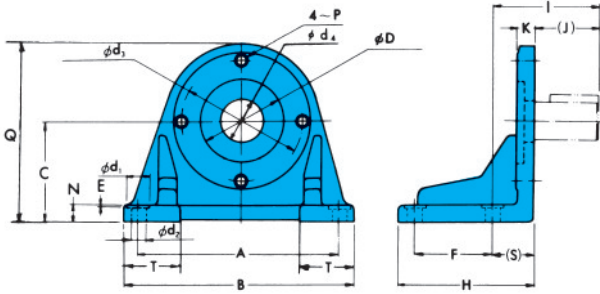

SAE-4BOLT-MOUNTING

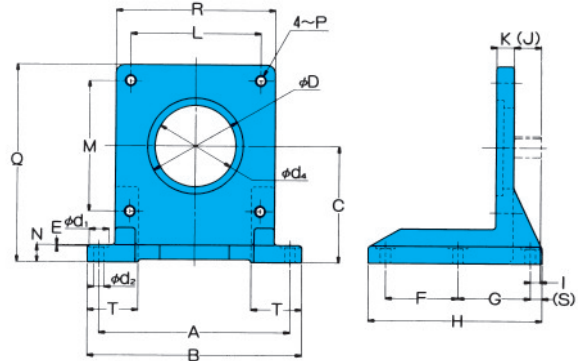

SAE-2BOLT-MOUNTING

Foot Mounting Kit Model No.	Applicable Pump Model No.		Accessories				Dimensions (mm)					
	SINGLE PUMP	DOUBLE PUMP	Bolt	Q'ty	Washer	Q'ty	A	B	C	E	F	H
IHM-2-10	IPH-2	-	TB-10 × 30	2	WP-10	2	127	152.5	69.8	1	50.8	96
IHM-4-10	IPH-3	-	TB-12 × 30	2	WG-12	2	220.7	246	107.95	1	114.3	140
IHM-4-10	IPH-4	-	TB-12 × 30	2	WG-12	2	220.7	246	107.95	1	114.3	140
IHM-22-10		IPH-22	TB-10 × 30	2	WP-10	2	171.45	204	107.95	1	95.25	150
IHM-44-10		IPH23, IPH-33	TB-12 × 30	2	WG-12	2	235	267	139.7	1	127	193
IHM-44-10		IPH-24, IPH-34, IPH-44	TB-12 × 30	2	WG-12	2	235	267	139.7	1	127	193
IHM-45-10	IPH-5	IPH-25, IPH-35, IPH-45	TB-16 × 40	2	WP-16	2	295.3	334	152.4	1	139.7	203
IHM-46-10	IPH-6	IPH-26, IPH-36, IPH-46	TB-20 × 50	2	WP-20	2	330.2	374	203.2	1	149.2	220.7

Foot Mounting Kit Model No.	Dimensions (mm)													Weight kg
	I	(J)	K	N	P	Q	(S)	T	φD	φd ₁	φd ₂	φd ₃	φd ₄	
IHM-2-10	74	41.5	17.5	13	M10	135	32.5	36.5	82.55	22	11	106.4	50	2.0
IHM-4-10	61.7	49	16	16	M12	195.5	12.7	53	101.6	22	11	146	40	5.5
IHM-4-10	74.7	62	16	16	M12	195.5	12.7	53	101.6	22	11	146	40	5.5
IHM-22-10	73.5	41	18	18	M10	180	32.5	50	82.55	22	11	106.4	40	6.5
IHM-44-10	89.5	45	20	20	M12	232	44.5	57.5	101.6	22	14	146	40	12.0
IHM-44-10	102.5	58	20	20	M12	232	44.5	57.5	101.6	22	14	146	40	12.0
IHM-45-10	104.5	60	25	25	M16	259	44.5	61	127	35	18	181	86	13.5
IHM-46-10	119.5	70	30	30	M20	337	49.5	64	152.4	37	20	228.6	100	22.0

*IHM-2-10, IHM-4-10, and IHM-45-10 are the same as PVS pump foot mounting PSM-101000, PSM102000, and PSM103000 respectively.

SAE-4BOLT-MOUNTING

Foot Mounting Kit Model No.	Applicable Pump Model No.	Accessories				Dimensions (mm)								
	DOUBLE PUMP	Bolt	Q'ty	Washer	Q'ty	A	B	C	E	F	G	H	I	
IHM-55-10	IPH-55	TH-20 × 50	4	WS-B-20	4	330	370	200	1	125	125	300	17	
IHM-66-10	IPH56, IPH-66	TH-24 × 60	4	WS-B-24	4	380	430	260	1	140	140	340	17	

Foot Mounting Kit Model No.	Dimensions (mm)														Weight kg
	(J)	K	L	M	N	P	Q	R	(S)	T	φD	φd ₁	φd ₂	φd ₃	
IHM-55-10	47	30	224.6	224.6	30	M20	340	275	20	90	165.1	34	18	140	32.0
IHM-66-10	52	40	247.5	247.5	40	M24	415	310	25	105	177.8	34	18	150	48.0

Air Bleed-off Valve

Equipping an air bleed-off valve on the pump's discharge side helps to simplify air bleeding during test operation.

JIS symbol

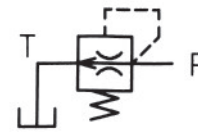

Specifications

- ① Air inside the pump and the suction pipe is exhausted rapidly when the pump is started up. When discharge pressure reaches 0.2MPa {2.0kgf/cm²} or greater after the pump intakes oil, a valve closes to prevent oil from leaking.
- ② Maximum operating pressure: 30MPa {306kgf/cm²}
- ③ Provide piping to ensure that the tank port is under the oil level surface.

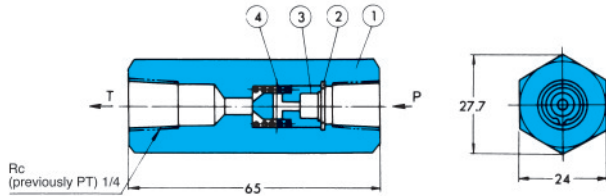

Understanding Model Numbers

CAB - T 02 - 1 - 11

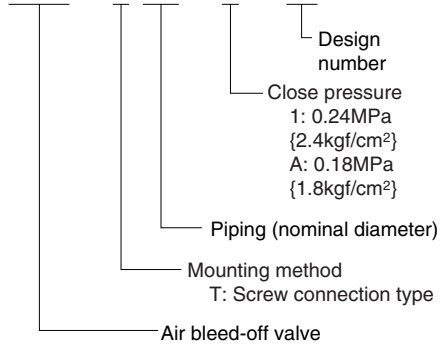

Part No.	Part Name	Q'ty
1	Valve body	1
2	Snap ring	1
3	Valve	1
4	Spring	1

- Note 1) If chattering occurs in a circuit when CAB-T02-1-11 is used, use CAB-T02-A-11 instead.
2) If chattering occurs in a circuit when CAB-T02-A-11 is used, use of a CAB air bleed-off valve is not required.

Application Examples

Example of Circuits that Require an Air Bleed-off Valve

- ① When using a Type 2 or Type 3 check valve (Sample Circuit A)
- ② When unload circuit function cannot be achieved (Sample Circuit A)
- ③ When the discharge sides of multiple pumps run together (Sample Circuit B)

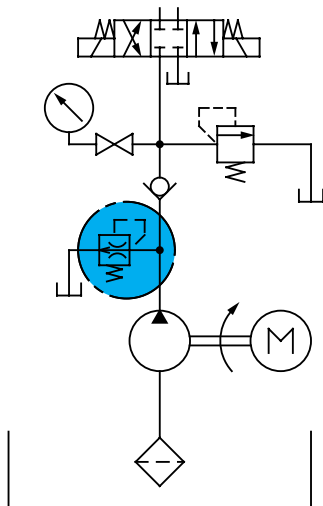

Circuit Diagram A

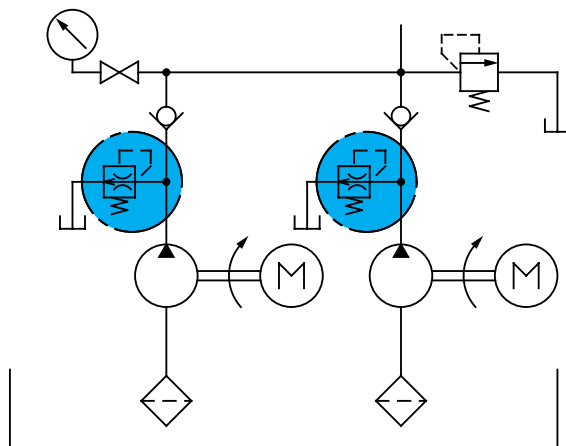

Circuit Diagram B