

# Hydraulic piston pumps

## Model 1: \*CY14-1B (F) Series Pumps

### Ordering Code:

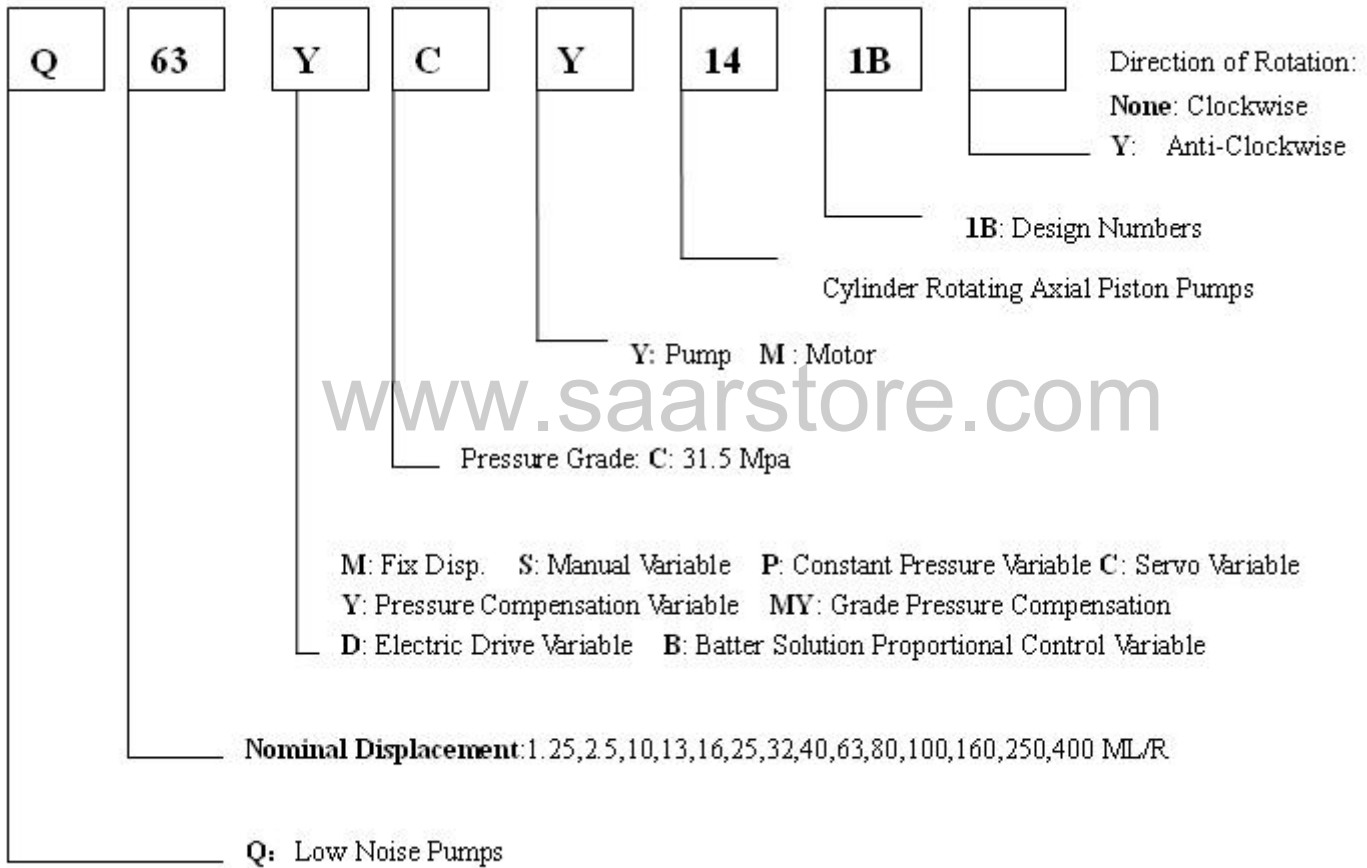

### Specification:

Type	Nominal Pressure (Mpa)	Nominal Displacement (CC/rev)	Theoretic Flow(LPM)		Max Drive power KW 1000rpm	Max, theoretic Torque(N.m)	
			1000rpm	1500rpm			
2.5	MCY14-1B	31.5	2.5	2.5	3.75	1.43	17.5
10	MCY14-1B	31.5	10	10	15	5.7	54.6
	SCY14-1B						
	YCY14-1B						
	PCY14-1B						
25	MYCY14-1B	31.5	25	25	37.5	14.1	134.9
	BCY14-1B						
	MCY14-1B						
	SCY14-1B						
40	YCY14-1B	31.5	40	40	60	22.6	201.5
	PCY14-1B						
40	MYCY14-1B	31.5	40	40	60	22.6	201.5
	BCY14-1B						
40	MCY14-1B	31.5	40	40	60	22.6	201.5
	SCY14-1B						

	YCY14-1B PCY14-1B						
	MYCY14-1B BCY14-1B						
63	MCY14-1B SCY14-1B	31.5	63	63	94.5	35.6	339.9
	YCY14-1B PCY14-1B						
	MYCY14-1B BCY14-1B						
80	MCY14-1B SCY14-1B	31.5	80	80	120	46.6	405.1
	YCY14-1B PCY14-1B						
	MYCY14-1B BCY14-1B						
160	MCY14-1B SCY14-1B	31.5	160	160	240	92.2	880.3
	YCY14-1B PCY14-1B						
	MYCY14-1B BCY14-1B						
250	MCY14-1B SCY14-1B	31.5	250	250	375	133.2	1272.4
	YCY14-1B PCY14-1B						
	MYCY14-1B BCY14-1B						
400	MCY14-1B SCY14-1B	31.5	400	400		199.5	1905.2
	YCY14-1B PCY14-1B						
	MYCY14-1B BCY14-1B						

When the nominal pressure is 31.5MPa, the displacement with 1.25、5、13、16、32、100ml/r also can offer.

MCY14-1B Series



Slanting disc type quota ram pump/Motor

STRUCTURE:

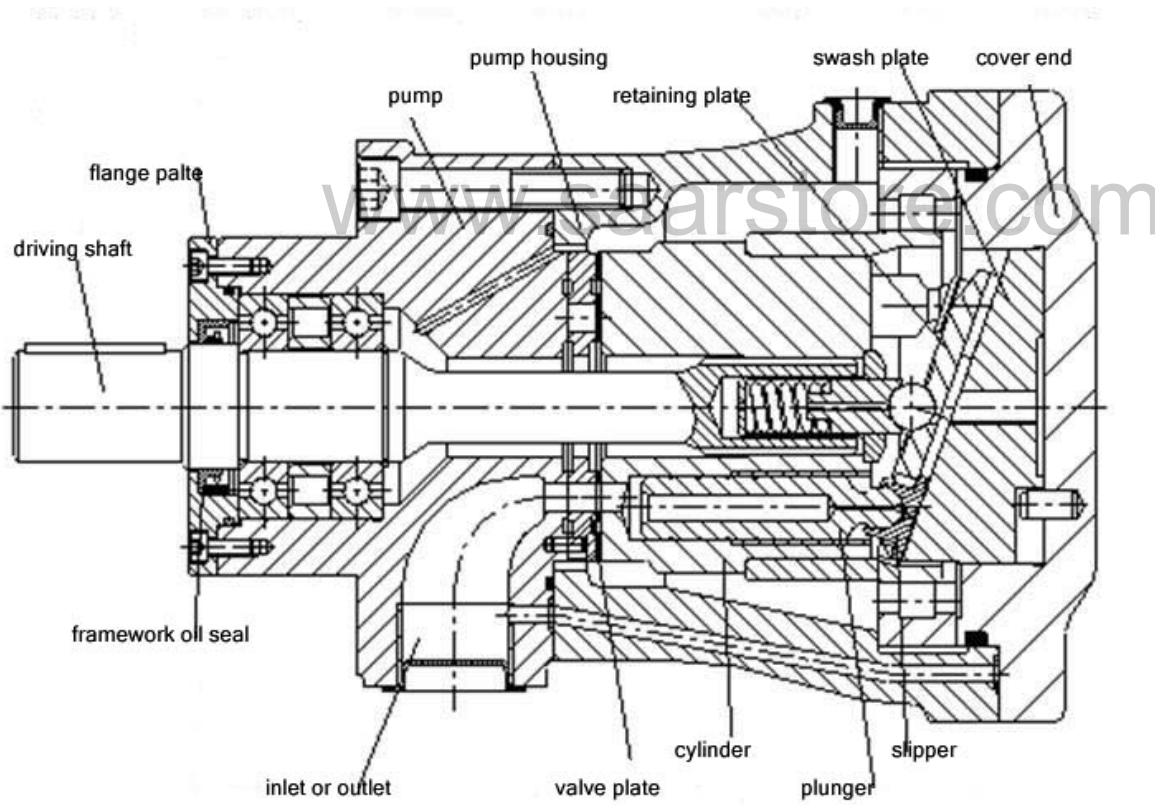

PRINCIPLE OF WORKING:

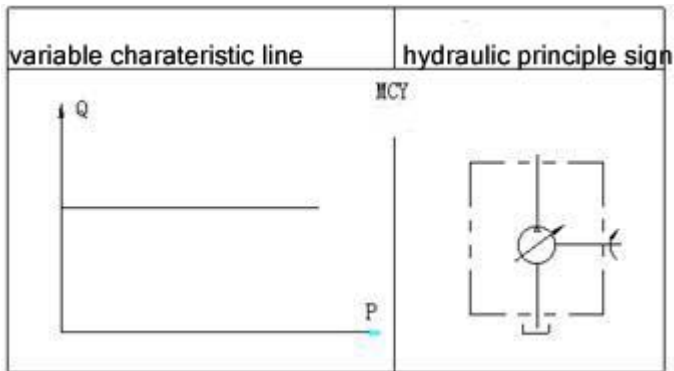

The main body are partial (sees also structure to split) revolves by the drive shaft impetus cylinder body, causes the u distribution to circle the drive shaft middle line rotation on the cylinder body seven plungers, presses through the central

column slippery module in slippery boots in variable (or slanting plate) on. Thus, the plunger revolves along with the cylinder but makes the reciprocal motion, completes blots and presses the oil movement.

In the quota organization the slanting plate fixes throughout on the quota end cover, cannot change the plunger the traveling therefore its current capacity is fixed. Should pump only must replace matches the oil disk also to be possible to take the oil r

**POWER COMPUTATION:**

$$N = \frac{QP}{60\eta} \text{ (Kw)}$$

Actual use electrical machinery power

Q—Current capacity L/min (Actual use current capacity)

P—Pressure MPa (Actual working pressure)

$\eta$ —Overall effectiveness index 0.85

the user may select the electrical machinery according to the actual use load after the upper row formula computation.

**DIMENSION SIZE:**

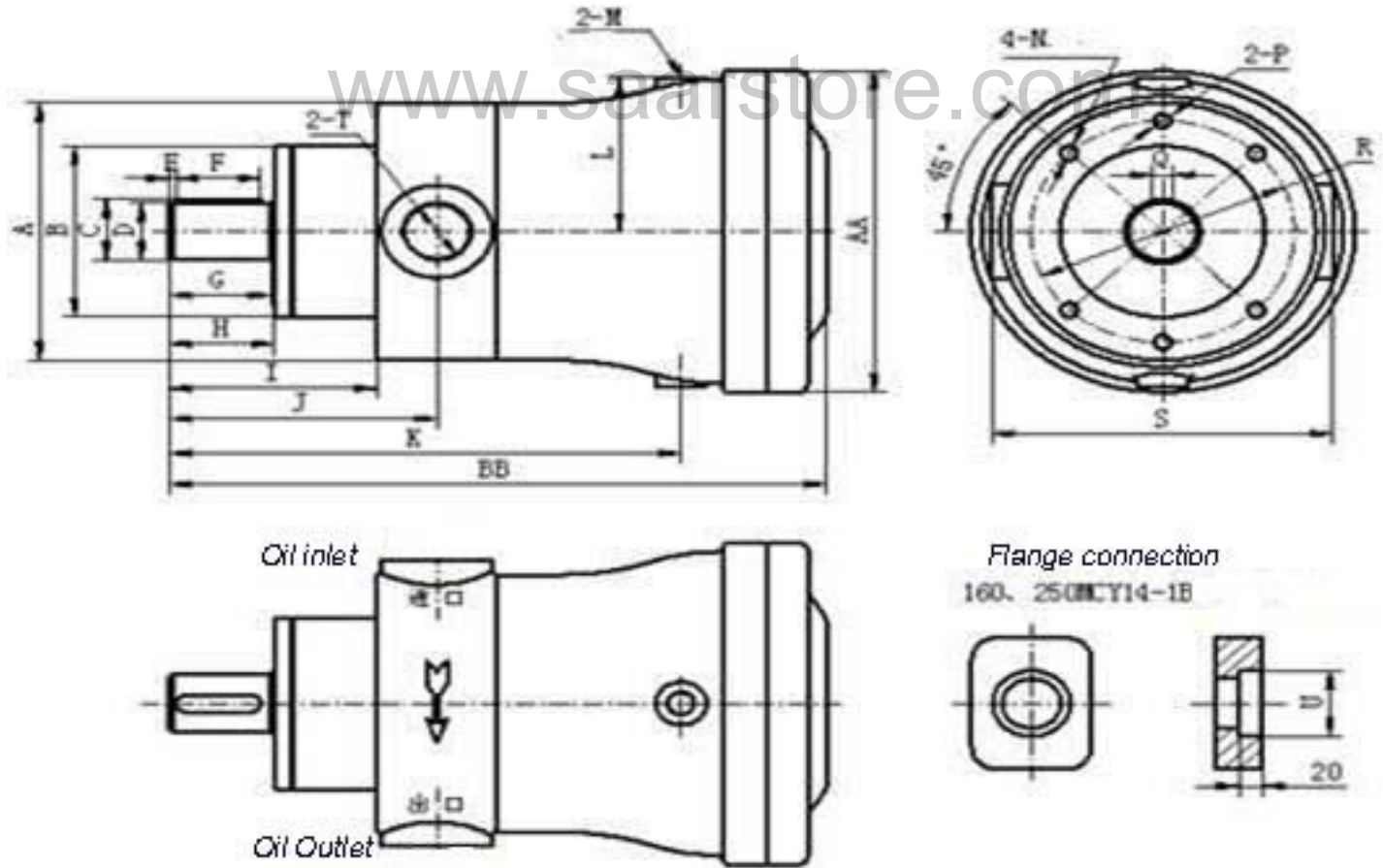

Dimension  Type	2.5MCY	10(16)MCY	25(40)MCY	63(80)MCY	160MCY	250(400)MCY
A	79 × 84	φ 125	φ 150	φ 190	φ 240	φ 280
B(f9)	φ 52	φ 75	φ 100	φ 120	φ 150	φ 180
C	15.8	27.5	32.5	42.8	59	63.9
D(h6)	φ 14	φ 25	φ 30	φ 40	φ 55	φ 60
E	3	4	4	4	4	5
F	20	30	45	50	100	100
G	25	40	52	60	106	110

H	26	41	54	62	110	112
I	62	86	104	122	180	212
J	77	109	134	157	230	272(277)
K	119	194	246	300	411	492(502)
L	44	71	83	108	141	170
M	M10 × 1	M14 × 1.5	M14 × 1.5	M18 × 1.5	M22 × 1.5	M22 × 1.5
N	M8	M10	M10	M12	M16	M20
P					M16	M20
Q(h9)	5	8	8	12	16	18
R	φ 80	φ 100	φ 125	φ 155	φ 198	φ 230
S	84	142	172	200	340	420
T	M18 × 1.5	M22 × 1.5	M33(M42) × 2	M42(M48) × 2	φ 55	φ 64( φ 66)
U					φ 64	φ 76
AA	φ 92	φ 150	φ 170	φ 225	φ 300	φ 360
BB	171	253	308	385	525	622(632)

# SCY14-1B Series



Slanting disc type manual variable ram pump/Motor

## Structure:

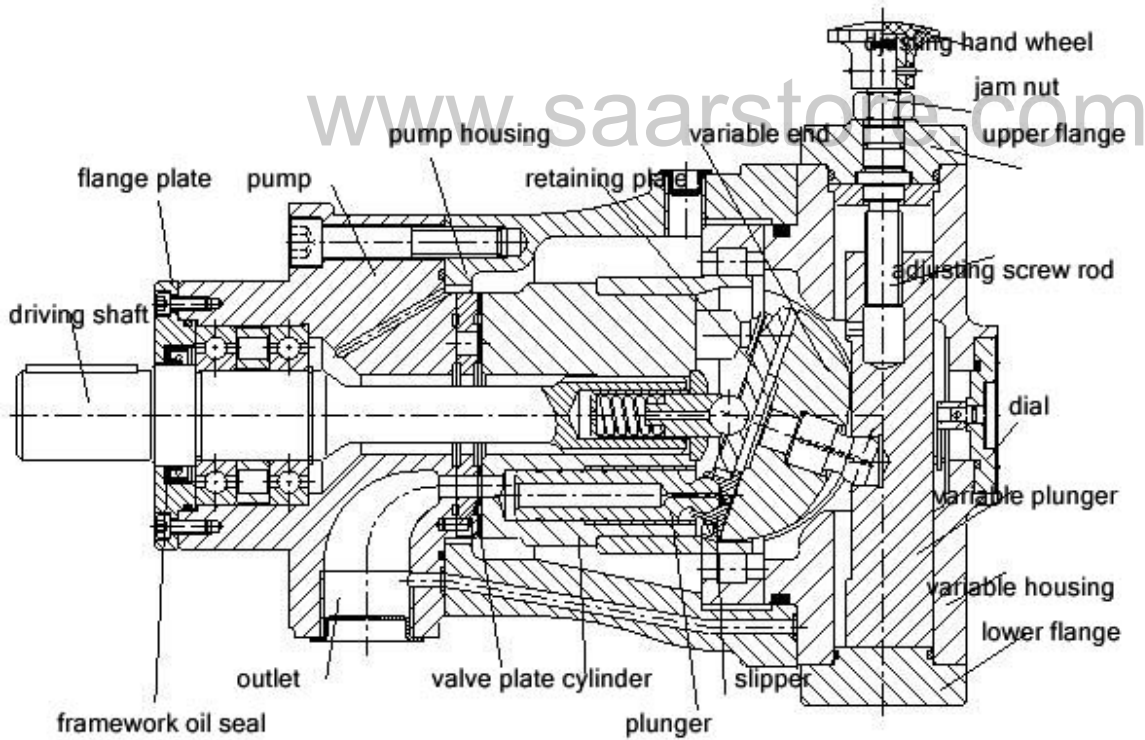

## Drawing:

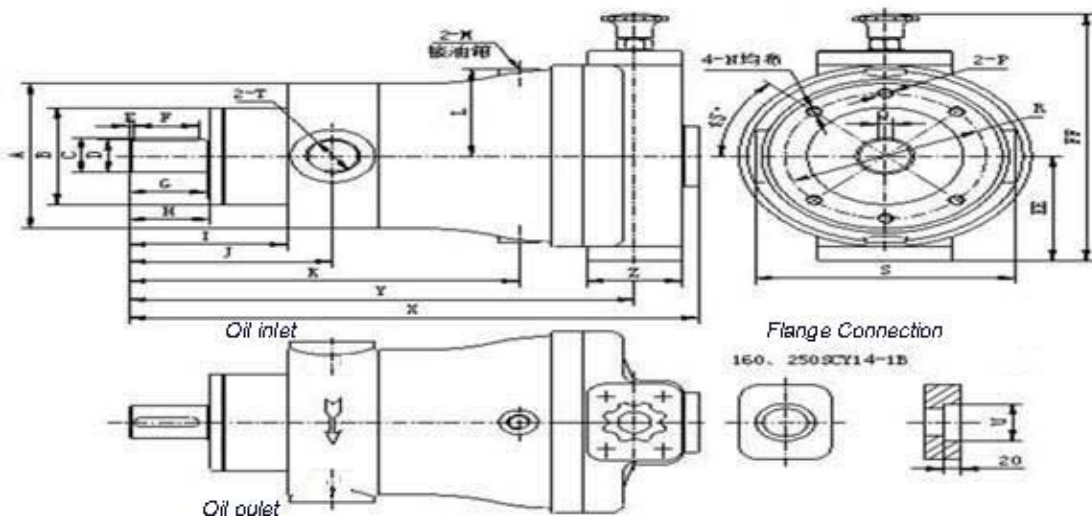

**DIMENSION SIZE:**

Dimension Type	10(16)SCY	25(40)SCY	63(80)SCY	160SCY	250(400)SCY
A	φ 125	φ 150	φ 190	φ 240	φ 280
B(f9)	φ 75	φ 100	φ 120	φ 150	φ 180
C	27.5	32.5	42.8	59	63.9
D(h6)	φ 25	φ 30	φ 40	φ 55	φ 60
E	4	4	4	4	5
F	30	45	50	100	100
G	40	52	60	106	110
H	41	54	62	110	112
I	86	104	122	180	212
J	109	134	157	230	272(277)
K	194	246	300	411	492(502)
L	71	83	108	141	170
M	M14 × 1.5	M14 × 1.5	M18 × 1.5	M22 × 1.5	M22 × 1.5
N	M10	M10	M12	M16	M20
Q(h9)	8	8	12	16	18
R	φ 100	φ 125	φ 155	φ 198	φ 230
S	142	172	200	340	420
T	M22 × 1.5	M33(M42) × 2	M42(M48) × 2	φ 55	φ 64( φ 66)
X	294	362	439	595	690(700)
Y	258	317	390	533	629(639)
Z	50	66	74	100	100
EE	91	101	130	165	203
FF	231	266	305	393	470



# YCY14-1B Series



Slanting disc type pressure compensation variable ram pump/Motor

## Structure:

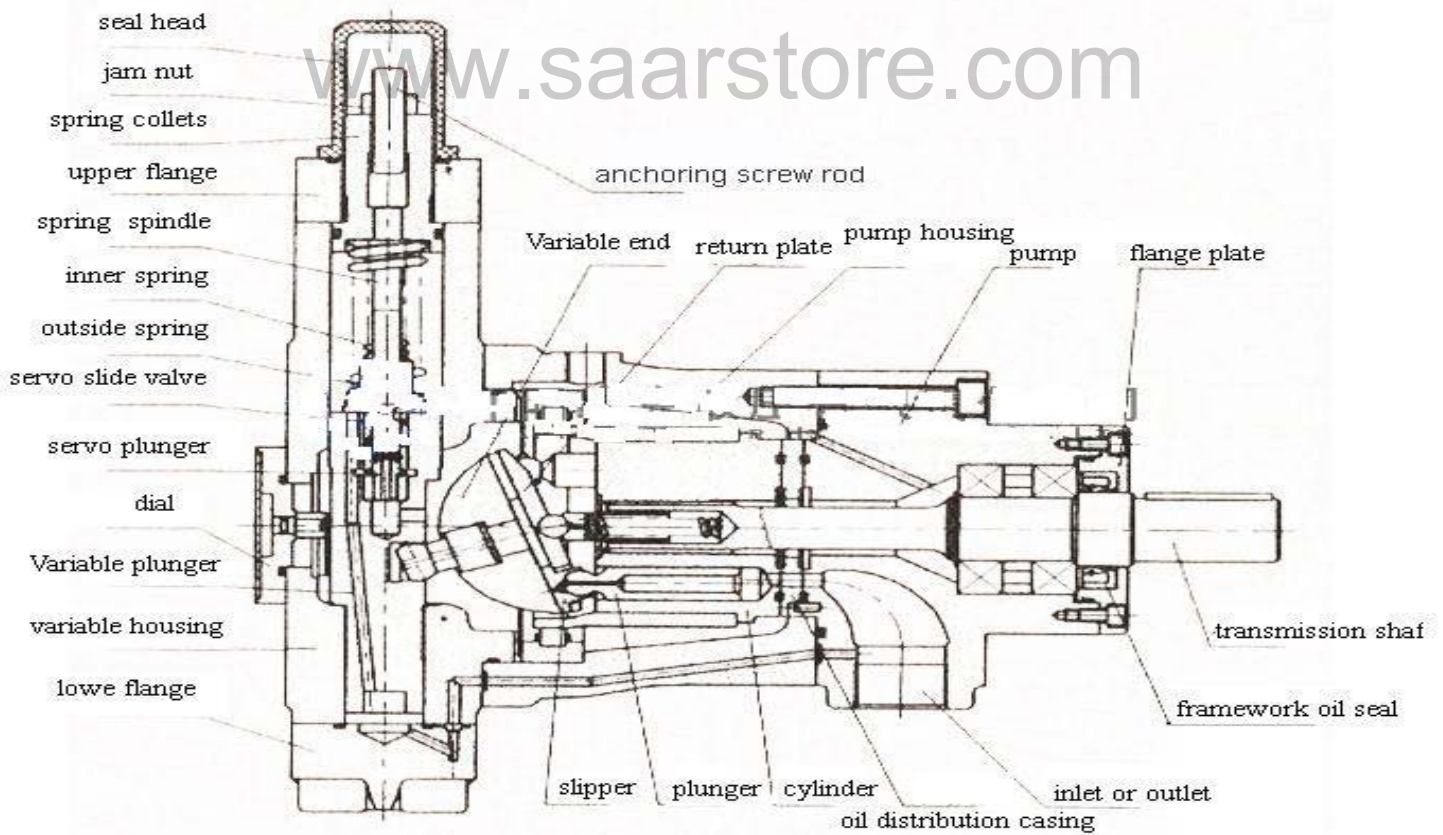

## Drawing:

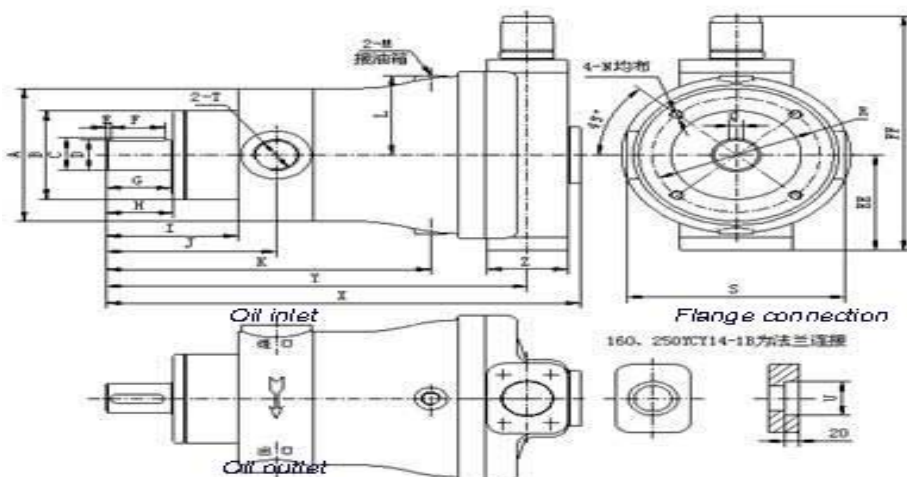



**Dimension**

Size/Type	10(16)YCY	25(40)YCY	63(80)YCY	160YCY	250(400)YCY
A	φ 125	φ 150	φ 190	φ 240	φ 280
B(f9)	φ 75	φ 100	φ 120	φ 150	φ 180
C	27.5	32.5	42.8	59	63.9
D(h6)	φ 25	φ 30	φ 40	φ 55	φ 60
E	4	4	4	4	5
F	30	45	50	100	100
G	40	52	60	106	110
H	41	54	62	110	112
I	86	104	122	180	212
J	109	134	157	230	272(277)
K	194	246	300	411	492(502)
L	71	83	108	141	170
M	M14 × 1.5	M14 × 1.5	M18 × 1.5	M22 × 1.5	M22 × 1.5
N	M10	M10	M12	M16	M20
P				M16	M20
Q(h9)	8	8	12	16	18
R	φ 100	φ 125	φ 155	φ 198	φ 230
S	142	172	200	340	420
T	M22 × 1.5	M33(M42) × 2	M42(M48) × 2	φ 55	φ 64( φ 66)
U				φ 64	φ 76
X	294	362	439	595	690(700)
Y	258	317	390	533	629(639)

Z	50	66	74	100	100
EE	100	120	140	173	210
FF	288	351	400	448	516

**MYCY14-1B Series**



The slanting disc type establishes grades the variable ram pump/Motor

**Structure:**

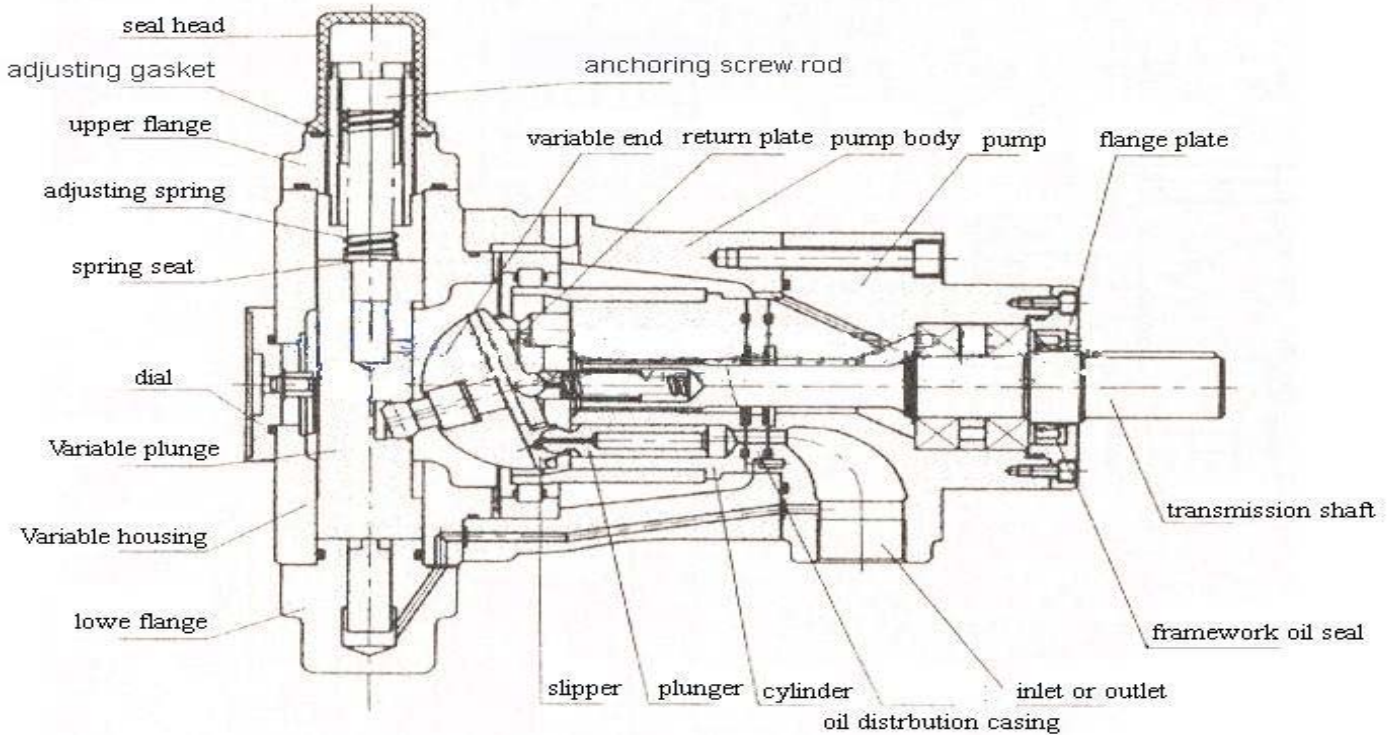

## Drawing and Dimension Size

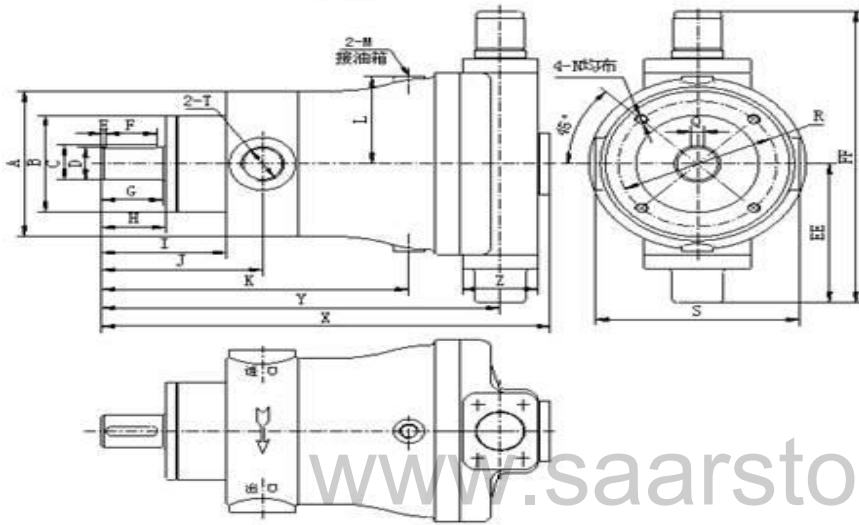

Dimension /type	10(16)MYCY	25(40)MYCY	63(80)MYCY
A	φ 125	φ 150	φ 190
B(f9)	φ 75	φ 100	φ 120
C	27.5	32.5	42.8
D(h6)	φ 25	φ 30	φ 40
E	4	4	4
F	30	45	50
G	40	52	60
H	41	54	62
I	86	104	122
J	109	134	157
K	194	246	300
L	71	83	108
M	M14 × 1.5	M14 × 1.5	M18 × 1.5
N	M10	M10	M12
Q(h9)	8	8	12
R	φ 100	φ 125	φ 155

S	142	172	200
T	M22 × 1.5	M33(M42) × 2	M42(M48) × 2
X	294	362	439
Y	258	317	390
Z	50	66	74
EE	127	153	188
FF	282	335	382

**BCY14-1B Series**

[www.saarstore.com](http://www.saarstore.com)



Slanting disc type battery solution proportional control variable ram pump/Motor

**Structure :**

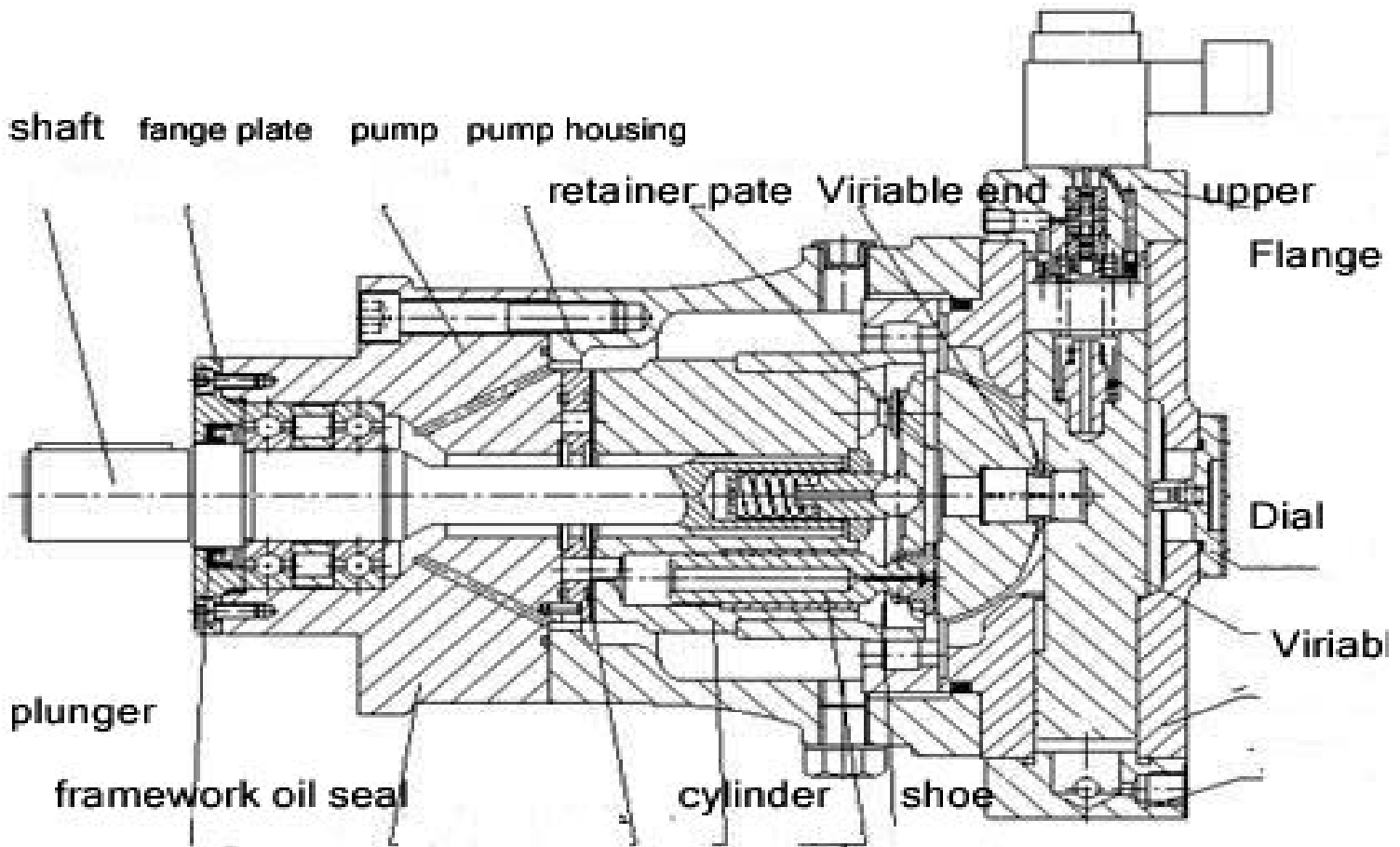

# Drawing and Dimension Size

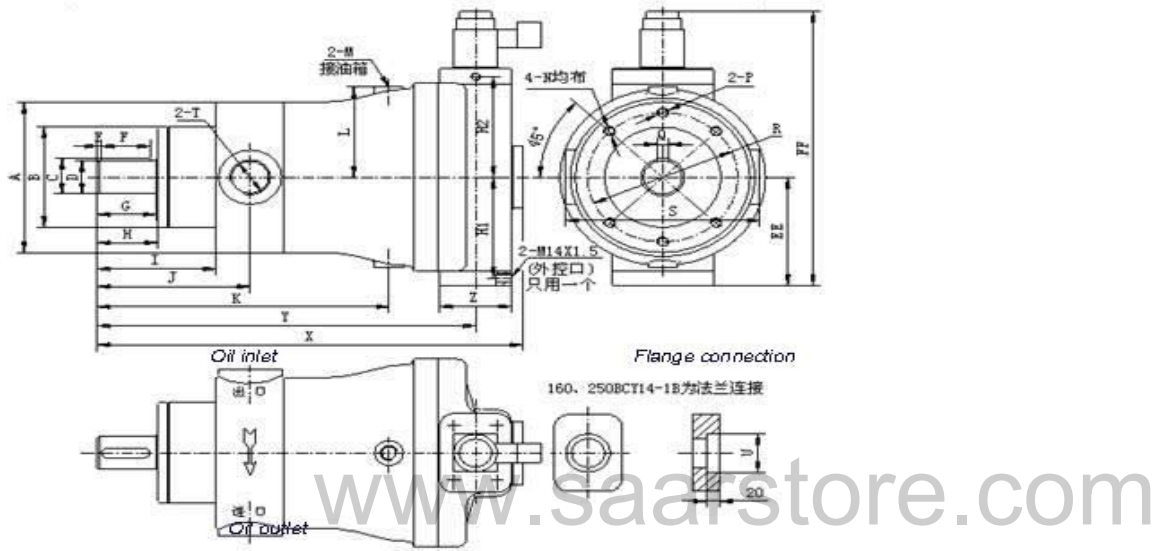

Dimension  Type	10BCY	25(40)BCY	63(80)BCY	160BCY	250(400)BCY
A	φ 125	φ 150	φ 190	φ 240	φ 280
B(f9)	φ 75	φ 100	φ 120	φ 150	φ 180
C	27.5	32.5	42.8	59	63.9
D(h6)	φ 25	φ 30	φ 40	φ 55	φ 60
E	4	4	4	4	5
F	30	45	50	100	100
G	40	52	60	106	110
H	41	54	62	110	112
I	86	104	122	180	212
J	109	134	157	230	272(277)
K	194	246	300	411	492(502)
L	71	83	108	141	170
M	M14 × 1.5	M14 × 1.5	M18 × 1.5	M22 × 1.5	M22 × 1.5
N	M10	M10	M12	M16	M20
P				M16	M20
Q(h9)	8	8	12	16	18

R	φ 100	φ 125	φ 155	φ 198	φ 230
S	142	172	200	340	420
T	M22 × 1.5	M33(M42) × 2	M42(M48) × 2	φ 55	φ 64( φ 66)
U				φ 64	φ 76
X	294	362	439	595	690(700)
Y	258	317	390	533	629(639)
Z	50	66	74	100	100
H1	65	80	127	157	193
H2	96.5	112	126	159	193
EE	100	110	140	173	210
FF	300	318	358	415	485

**PCY14-1B Series**



Slanting disc type constant pressure variable ram pump

**Structure:**

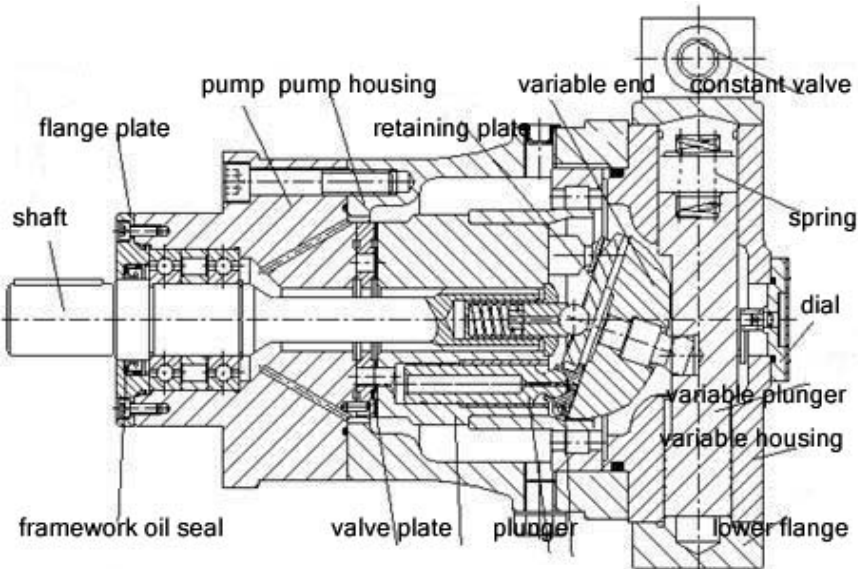

**Drawing:**

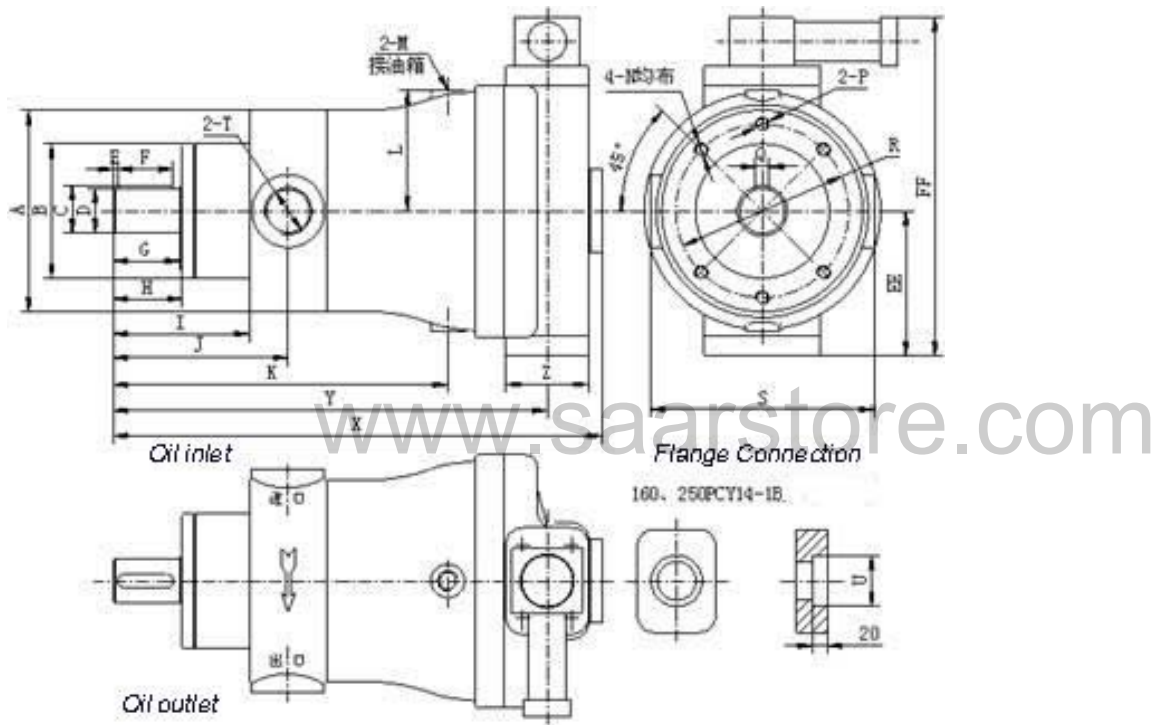

**Dimension Size:**

Dimension  Type	10PCY	25(40)PCY	63(80)PCY	160PCY	250(400)PCY
A	φ 125	φ 150	φ 190	φ 240	φ 280
B(f9)	φ 75	φ 100	φ 120	φ 150	φ 180
C	27.5	32.5	42.8	59	63.9
D(h6)	φ 25	φ 30	φ 40	φ 55	φ 60
E	4	4	4	4	5
F	30	45	50	100	100
G	40	52	60	106	110
H	41	54	62	110	112
I	86	104	122	180	212
J	109	134	157	230	272(277)
K	194	246	300	411	492(502)
L	71	83	108	141	170
M	M14 × 1.5	M14 × 1.5	M18 × 1.5	M22 × 1.5	M22 × 1.5



N	M10	M10	M12	M16	M20
P				M16	M20
Q(h9)	8	8	12	16	18
R	φ 100	φ 125	φ 155	φ 198	φ 230
S	142	172	200	340	420
T	M22 × 1.5	M33(M42) × 2	M42(M48) × 2	φ 55	φ 64( φ 66)
U				φ 64	φ 76
X	294	362	439	595	690(700)
Y	258	317	390	533	629(639)
Z	50	66	74	100	100
EE	101	120	140	173	210
FF	255	280	329	396	465

### CCY14-1B Series



CCY14-1B

Slanting disc type servo variable ram pump

### Structure and Drawing:

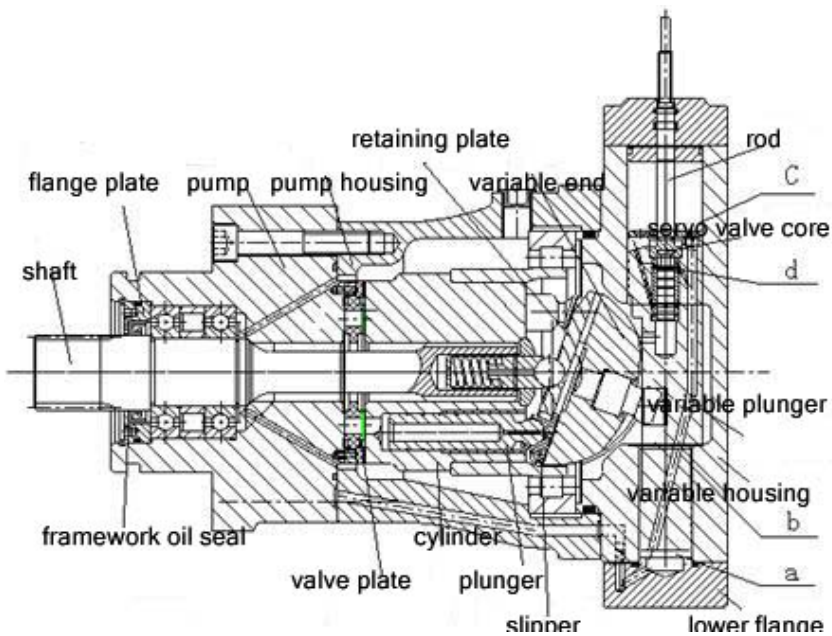

**Dimensions:**

